

Cobra MARINE™



Owner's Manual



MARINE CHART PLOTTER MC 600Ci/600Cx

Nothing Comes Close To A Cobra®

Printed in Italy
Part No. 480-272-P
Version A



www.cobra.com



MC 600Cx and MC 600Cx EU

MC 600Ci and MC 600Ci EU



Owner's Manual



All rights reserved. No part of this publication may be reproduced or distributed in any form or by any means, or stored in a database or retrieval system, without prior written permission of the publisher.

©2006 Cobra Electronics Corporation™
6500 West Cortland Street, Chicago
Illinois 60707 USA

©2006 Cobra® Electronics Europe Limited
Dungar House, Northumberland Avenue, Dun Laoghaire
County Dublin, Ireland

Cobra®, NightWatch®, Nothing Comes Close to a Cobra® and the snake design are registered trademarks of Cobra Electronics Corporation, USA.

Cobra Electronics Corporation™, CobraMarine™ and iASAP™ are trademarks of Cobra Electronics Corporation, USA.
C-MAP™, C-MAP Navigation Technology, C-MAP NT MAX™ and C-MAP NT+™ are registered trademarks of C-MAP S.r.l.



Our Thanks to You and Customer Assistance

Introduction

**Thank you for purchasing a CobraMarine™ MC 600Ci or MC 600Cx chartplotter.
Properly used, this product will give you many years of reliable service.**

How Your Cobra® Chartplotter Works

The CobraMarine™ chartplotter is a state-of-the-art computerized electronic chart system, designed as a sophisticated navigation aid. User friendly operations make the chartplotter easy to operate. All calculations and information necessary for the navigation are performed and displayed on the screen quickly and accurately providing all of the capabilities of a conventional GPS but with the added benefit of a powerful electronic chart display. The cartographic information is obtained from C-MAP™ C-CARDs (cartography data cards) that are available through your local dealer. For additional information on C-MAP™ Cartography visit web site at **www.c-map.com**.



Customer Assistance

CUSTOMER ASSISTANCE INFORMATION

Should you encounter any problems with this product, or not understand its many features, please refer to this Owner's Manual. If you require further assistance after reading this Owner's Manual, Cobra Electronics Corporation™ offers the following customer assistance services:

For Assistance in the U.S.A

Automated Help Desk English only.
24 hours a day, 7 days a week 773-889-3087 (phone).

Customer Assistance Operators English and Spanish.
8:00 a.m. to 6:00 p.m. through Fri. (except holidays) 773-889-3087 (phone).

Questions English and Spanish.
Faxes can be received at 773-622-2269 (fax).

Technical Assistance

English only: www.cobra.com (on-line: Frequently Asked Questions).
English and Spanish: productinfo@cobra.com (e-mail).

For Assistance Outside the U.S.A

Contact Your Local Dealer or Distributor. Please see www.cobra.com for contact information.



Control and Indicators

Introduction

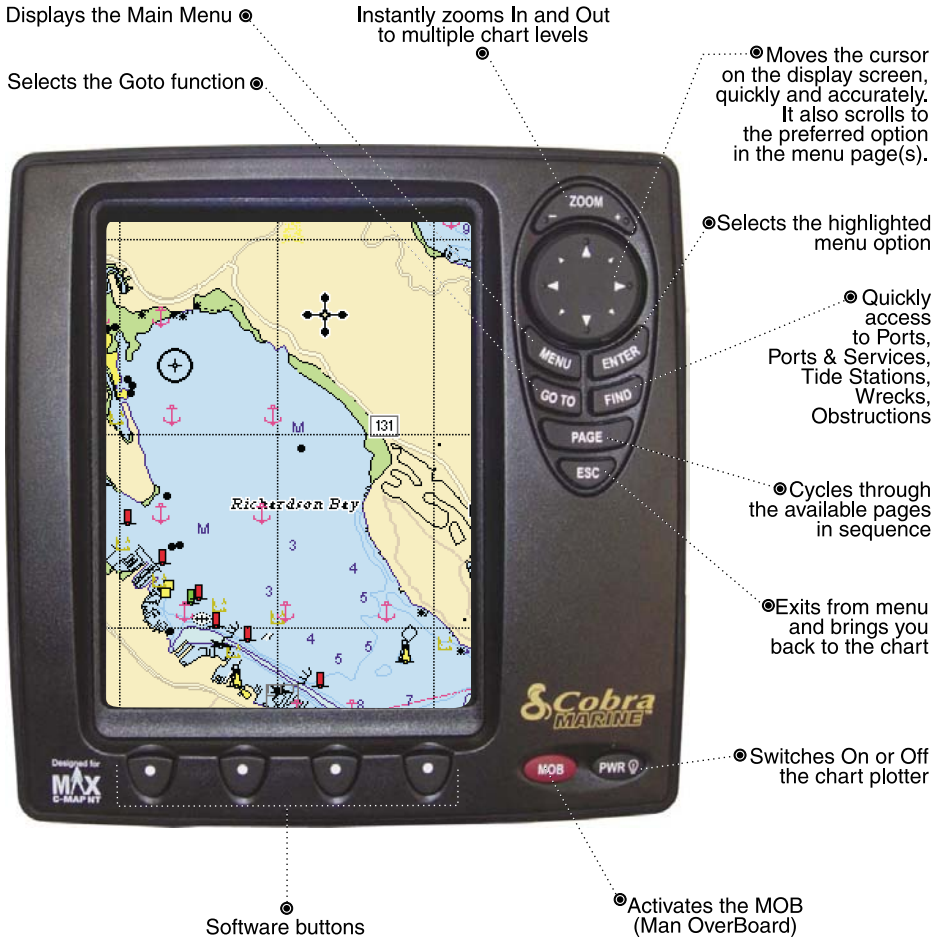

SOFTWARE BUTTONS FUNCTIONALITY

The software buttons have different functions according to the modes of operation: their labels for the current functions, are shown on the screen right above the buttons. They can also be used like FM radio preset buttons to save quick access to your favorite pages. When pressing the **ESC** button the four software button, labels disappear.



SOFTWARE FEATURES

- Detailed Base Map Included
- 3D Mapping (view charts in either top down or new 3D perspective modes)
- 12 Channel WAAS GPS with iASAP™
- Sunlight and NightWatch™ Modes
- Easy surfing among the available pages (Data, Highway, Sun & Moon, Split, GPS Status, System and Welcome pages)
- Fish Finder and Combo pages (available with Fish Finder device connected)
- DSC Calling integration
- 1000 Waypoints and 50 Routes (50 Waypoints/Route)
- Create, Move, Insert, Edit or Erase Waypoint
- Create, Save, Name, Edit or Follow a Route
- Navigation to Goto
- Route Data Report and User Points (Marks/Waypoints) List pages
- Find Ports Services, Ports, Tide Stations, Wrecks, Obstructions, Coordinates and User Points
- Display Tide Info and Tide Graph page
- Automatic Info on cartographic objects and User Points
- Display vessel's position, direction and Track
- 10 Tracks with 16 Color Options
- Alarms Handling (Anchor Drag, Arrival, Off Course, Proximity, Depth, Etc.)
- Man OverBoard (MOB) to navigate back to a missing person or object
- Demo Modes

TECHNICAL SECIFICATIONS

- Power Consumption : 10 - 35 V
- Interface : NMEA-0183
- Autopilot Interface : NMEA-0180, NMEA-0180/CDX, NMEA-0183
- Display : 6" Color TFT with Anti-Reflective Coating (*Active Area 5.7"*)
- Display Resolution : 240 x 320 pixels
- Cartography : C-MAP NT MAX™ or C-MAP NT+™ C-CARDs
- Operating Range : 0/+55 degree Celsius
- Water Proof Specification : Submersible to IPX7 or JIS7
- Memory : Non volatile with battery back-up
- Keyboard : Silicon rubber, backlight
- Weight : 630 gr.



WARNINGS AND CAUTIONS

Before using your CobraMarine™ MC 600C chartplotter please read these general precautions and warnings.



WARNING

Electronic charts displayed by the chartplotter are believed to be accurate and reliable, but they are not intended to replace official charts which should remain your main reference for all the matters related to the execution of a safe navigation. For this reason we would like to remind you that you are required to carry on board and use the officially published and approved nautical charts.



CAUTION

- Please read through this manual before the first operation. If you have any questions, please contact the customer service or your local chartplotter dealer or distributor.
- Extensive exposure to heat may result in damage to the chartplotter.
- Connection to the power source with reversed polarity will damage the chartplotter severely. This damage is not covered by the warranty.
- Do not disassemble. The chartplotter contains dangerous high voltage circuits which only experienced technicians MUST handle.
- The C-MAP™ C-CARDs are available from your local dealer.
- Exposure of the display to UV rays may shorten the life of the liquid crystals used in your plotter. This limitation is due to the current technology of the LCD displays.
- Avoid overheating which may cause loss of contrast and, in extreme cases, a darkening of the screen. Problems which occur from overheating are reversible when temperature decreases.

SCREEN CLEANING PRECAUTIONS

Cleaning your chartplotter screen is a very important operation and must be done carefully, as the window's surface is covered with an antireflective coating. The following is the cleaning procedure: you use a tissue or lens tissue and a cleaning spray containing Isopropanol (a normal spray cleaner sold for PC screens, for example PolaClear by Polaroid). Fold the tissue or lens tissue into a triangular shape, moisten the tip and use the index finger behind a corner to move the tissue across the surface, in overlapping side to side strokes. If the tissue is too wet, a noticeable wet film will be left in its path and you will need to repeat the process. If too dry, the tissue won't glide easily, and may damage the surface.



WHAT IS IN THE BOX?

When the package containing the chartplotter is first opened, please check it for the following contents (if any parts are missing contact the dealer the chartplotter was purchased from):

- CobraMarine™ MC 600C chartplotter
- Power Data Cable
- Tilt and Swivel Mounting Bracket
- Two Removable Faceplates
- Owner's Manual
- Quick Reference Guide
- External GPS Antenna with 10 Meter Cable (ONLY on MC 600Cx model)
- Flush Mount Kit (ONLY on MC 600Cx with model)

MC 600C Chart Details

The chartplotter has a built-in world map that can be used for Route planning. To use the chartplotter as a navigation aid, charts are required with detailed information for the area. This chart cartridge is called a C-CARD. C-CARDS are available from your local C-MAP™ dealer. See Chapter 6 for the insert/remove C-CARD procedure. The C-CARD can be inserted by removing the faceplate.

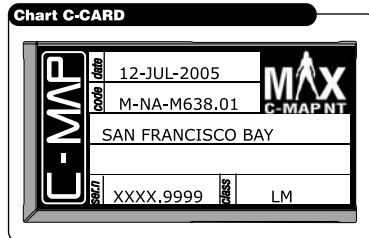



1. MANUAL ORGANIZATION

1.1. TABLE OF CONTENTS

INTRODUCTION	A1
OUR THANK S TO YOU	A1
CUSTOMER ASSISTANCE	A1
CONTROL AND INDICATORS	A2
SOFTWARE BUTTONS FUNCTIONALITY	A2
SOFTWARE FEATURES	A3
TECHNICAL SPECIFICATIONS	A3
WARNINGS AND CAUTIONS	1
SCREEN CLEANING PRECAUTIONS	1
WHAT IS IN THE BOX?	2
MC 600C Chart Details	2
1. MANUAL ORGANIZATION	3
1.1. TABLE OF CONTENTS	3
1.2. GENERAL OPERATION	7
1.2.1. Button Conventions Used	7
1.2.2. Menu Description	7
1.2.3. Selecting an option	7
1.2.4. Alphanumeric Input Procedure	8
2. BASIC OPERATION	10
2.1. SWITCHING ON/OFF	10
2.1.1. Switching On	10
2.1.2. Switching Off	10
2.1.3. Auto power On Description	10
2.2. INITIAL SETUP	10
2.2.1. Definitions of Selections	11
2.3. ADJUSTING THE BACKLIGHTING AND CONTRAST	12
2.4. PAGE SURFING	13
2.4.1. Pages selection	13
2.5. DEMO MODE	14
2.5.1. Full Demo	14
2.5.2. Demo a Route	14
2.5.3. Custom Demo	14
2.6. MOVING AND ZOOMING ON CHART	14
2.6.1. Pan	14
2.6.2. Zoom	15
2.6.3. Esc back to chart	15
2.7. CHANGING DATA FIELDS ON MOST PAGES	15
2.7.1. Number of Data Fields	15
2.7.2. Change Data Fields	16
2.7.3. Available Data Options	17
2.8. CREATING A USER POINT	17
2.8.1. Creating a New Waypoint	17
2.8.2. Creating a New Mark	18
2.9. CREATING A BASIC ROUTE	18
2.10. USING GOTO	19
2.11. USING FIND	19



Table of Contents

Introduction

2.12. USING MOB	20
2.12.1. Inserting MOB	20
2.12.2. Deleting MOB	20
3. PAGE INFORMATION AND OPERATION	21
3.1. PAGE SELECTION AND PRESETS - SETUP	21
3.2. WELCOME PAGE	22
3.2.1. Operations	22
3.3. CHART ONLY PAGE	24
3.3.1. Description	24
3.3.2. Operations	24
3.3.2.1. Available Layouts of CHART Page	24
3.3.2.2. Changing Data Options	24
3.3.2.3. Operations on User Points	25
3.3.2.4. Software Buttons	25
3.3.3. Menu	25
3.4. DATA PAGE	27
3.4.1. Description	27
3.4.2. Operations	27
3.4.2.1. Available Layouts of DATA Page	27
3.4.2.2. Changing Data Options	27
3.4.2.3. On Screen Instructions	28
3.4.3. Menu	28
3.5. HIGHWAY PAGE	30
3.5.1. Description	30
3.5.2. Operations	30
3.5.2.1. Available Layouts of HIGHWAY Page	31
3.5.2.2. ZOOM IN AND ZOOM OUT	31
3.5.3. Menu	31
3.6. SUN AND MOON PAGE	32
3.6.1. Description - "Telling" Tide	32
3.6.2. Operations	32
3.6.2.1. Available Layouts of SUN and MOON Page	33
3.6.2.2. Finding the Nearest Tide Stations	33
3.6.2.3. Finding a Tide Station on a map	33
3.6.2.4. Changing the date for the Tide Chart	34
3.6.2.5. Various Animation Options	34
3.7. FISH FINDER PAGE	35
3.7.1. Description	35
3.7.1.1. Understanding the Fish Finder Echogram	37
3.7.2. Operations	38
3.7.2.1. Available Layouts of FISH FINDER Page	38
3.7.2.2. Changing Data Options	38
3.7.2.3. Split Mode of the FISH FINDER Page	38
3.7.3. Menu	38
3.8. COMBO MODE PAGE	41
3.8.1. Description	41
3.8.2. Operations	41
3.8.2.1. Moving the location of the Chart Window	41
3.8.2.2. Available Layouts of COMBO MODE Page	42
3.8.2.3. Changing Data Options	42
3.8.2.4. Changing the Size of Windows	42
3.8.3. Screen Control	43



Table of Contents

Introduction

3.9.	SPLIT MODE PAGE	44
3.9.1.	Description	44
3.9.1.1.	Available Layouts of SLIT MODE Page	44
3.9.1.2.	Changing Data Options	44
3.9.1.3.	Changing the size of windows	45
3.9.1.4.	Changing the Screen Control	45
3.9.2.	Menu	45
3.9.2.1.	CHART Page	45
3.9.2.2.	HIGHWAY Page	45
3.9.2.3.	FISH FINDER Page	45
3.10.	GPS PAGE	46
3.10.1.	Description	46
3.10.1.1.	Changing Data Options	46
3.10.2.	Menu	47
3.11.	SYSTEM PAGE	48
3.11.1.	Description	48
3.11.2.	Each Setting Description	48
4.	ADVANCED OPERATION	49
4.1.	MEASURE FUNCTION	49
4.2.	ADVANCED WAYPOINT OPERATIONS	49
4.2.1.	Deleting a Waypoint	49
4.2.2.	Moving a Waypoint	50
4.2.3.	Inserting a Waypoint	50
4.2.4.	Editing a Waypoint	50
4.3.	ROUTE OPERATIONS	50
4.3.1.	Selecting existing and Naming new Routes	51
4.3.2.	Basic Route List Operations	51
4.4.	USING TRACK	52
4.5.	USER POINTS LIST	53
4.5.1.	Selecting Existing and naming new User Points	53
4.5.2.	Basic User Point List Operations	53
4.6.	USER C-CARD OPERATIONS	54
4.6.1.	User C-CARD Page	54
4.6.2.	Formatting User C-CARD	54
4.6.3.	Saving file on User C-CARD	55
4.6.4.	Loading file from User C-CARD	55
4.6.5.	Deleting file from User C-CARD	55
4.7.	INFO	56
4.7.1.	Setting Automatic Info	56
4.7.2.	Selecting Automatic Info	56
4.7.3.	Info on objects with Pictures	56
4.7.4.	Info Tree and Expanded Info page	57
4.8.	CURRENT PREDICTIONS	57
4.9.	DYNAMIC NAV AIDS	57
4.10.	PICTURES	58
4.11.	DSC CALLING	58
4.11.1.	Advanced DSC for VHF Radio with NMEA 0183 Output	59
4.11.2.	Contact List	59
5.	SYSTEM PAGE SETTINGS	60
5.1.	SCREEN SHOT AND DESCRIPTIONS	60
5.2.	OPERATIONS BY SETTING GROUP	60



Table of Contents

Introduction

5.2.1. Display Settings	60
5.2.2. Chart Settings	61
5.2.2.1. Chart Presentation	61
5.2.2.2. Depth Presentation	63
5.2.2.3. Land Presentation	64
5.2.2.4. Advanced Chart Settings	64
5.2.3. General	67
5.2.4. Fish Finder Settings	67
5.2.4.1. Display Settings	68
5.2.4.2. Sensitivity Settings	68
5.2.4.3. Transducer Settings	69
5.2.5. Alarm Settings	70
5.2.5.1. General Alarms	70
5.2.5.2. GPS Alarms	70
5.2.5.3. Fish Alarms	71
5.2.6. Units	71
5.2.7. Pages On/Off	72
5.2.8. GPS Settings	72
5.2.9. Demo	73
5.2.9.1. Custom Demo	73
5.2.10. Com Settings	74
5.2.11. About	75
6. INSTALLATION	76
6.1. BASIC	76
6.1.1. Chartplotter Dimensions	76
6.1.2. C-CARD Inserting and Removing	76
6.1.3. Chartplotter Installation and Removing	77
6.1.4. Wiring and Connectors	77
6.2. ADVANCED	78
6.2.1. External NMEA Connection	78
6.2.2. GPS Connection (on MC 600Cx with External GPS)	78
6.2.3. Autopilot and Basic DSC VHF Connection	78
6.2.4. External Alarm Connection	79
6.2.5. Fish Finder	79
6.3. MOUNTING THE GPS ANTENNA (ONLY on MC 600Cx model)	79
6.3.1. Antenna Flush Mounting	80
7. MAINTENANCE	81
7.1. SYSTEM TEST	81
8. OPTIONAL ACCESSORIES	82
8.1. PC-PLANNER	82
8.2. MF 2500 FISH FINDER	82
8.2.1. Transducers	82
9. APPENDIX	83
9.1. TERMS	83
9.2. GPS	90
9.2.1. How GPS Works	90
9.2.2. Position Fixing Accuracy: HDOP	91
9.3. WORLD CITY TIME ZONES	93
INDEX	94



1.2. GENERAL OPERATION

1.2.1. Button Conventions Used

Throughout this Owner's Manual, the hardware buttons on the MC 600C are shown in bold capital letters, for example **ENTER**; the software buttons are shown in bold small capital letters, for example **Edt**. See the following pictures.

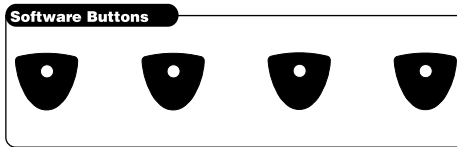
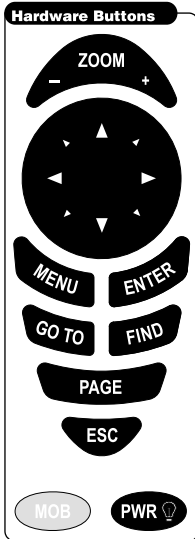

NOTE

For software buttons, the function varies depending on text listed above the button. Press and hold for three (3) seconds during most operation to "save" the page you are on.

Any menu operation and function activation in this Owner's Manual is related to both MC 600Cx and MC 600Ci chartplotter models. Whenever it is necessary, a note has been inserted for the model with differences.

1.2.2. Menu Description

Many of the options listed under the Page Information and Operation Instructions should be read from start to finish. Duplicate items are not mentioned for each Page Operation. Example, Menu Item descriptions will not be listed for each page if they have already been described on the previous pages.

1.2.3. Selecting an option

When a menu window is shown on the screen, the procedure to follow for selecting the desired option is the same for every menu. For example, if you



have activated the menu from the **CHART Page** (by pressing the **MENU** button) to select the option you want, “**NUMBER OF DATA FIELDS**” option, follow the procedure listed below:

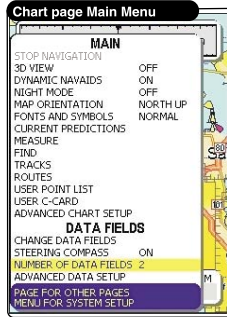

1. Use the **UP** and **DOWN CURSOR** buttons to select the desired option, “**NUMBER OF DATA FIELDS**”.
2. Press the **ENTER** button: a drop down box appears with the available selections “**2**”, “**4**”, “**6**”, “**HIDE**”.

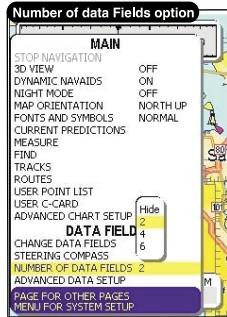

3. Use the **UP** and **DOWN CURSOR** buttons to select a desired choice.
4. Press the **ENTER** button to confirm, or the **ESC** button to abort and return to the previous settings.



NOTE

Pressing the **RIGHT CURSOR** button will sometimes perform like the **ENTER** button during this operation.

1.2.4. Alphanumeric Input Procedure

Information is keyed into the chartplotter for example when editing a Waypoint (see the following picture), or when entering Setup information.



When the field is highlighted:

1. Use the **RIGHT** or **LEFT** software buttons at the bottom to highlight the field you would like to change.
2. Use the **UP**, **DOWN**, **RIGHT** or **LEFT CURSOR** buttons to step through the available characters until the desired character is highlighted.
3. Press the **ENTER** button to confirm; the selected character appears in the highlighted field on the top line.
4. Repeat this procedure until you complete your entry.
5. Press the **SAVE** software button when the entry is complete.

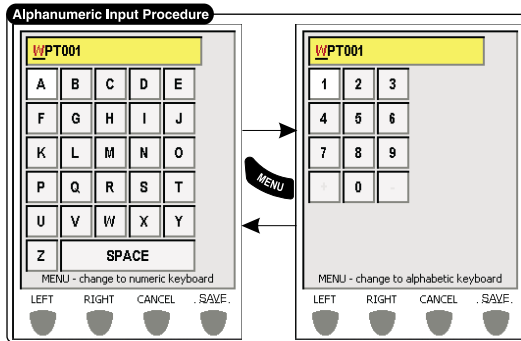

NOTE

This keypad is designed to reduce the number of button presses needed naming points and entering data. It can be disabled and the more conventional method used. If desired, it is disabled from the General settings of the **SYSTEM Page**.



2. BASIC OPERATION

NOTE

Refer to the foldout on the front cover to identify the various controls and indicators on your chartplotter.

2.1. SWITCHING ON/OFF

Before powering On the chartplotter, check for the correct voltage (10-35 volt dc).

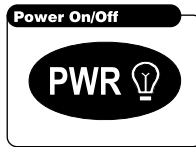

2.1.1 Switching On

Press and hold the **PWR** button for one (1) second. The chartplotter shows you the Logo Screen, Caution Notice (press the **ENTER** button) and then the **WELCOME Page** in sequence. See the **INITIAL SETUP Page** instruction for first time switch On instructions.

2.1.2 Switching Off

Press and hold the **PWR** button for three (3) seconds. A countdown timer appears on the screen, if you release the button before the countdown timer reaches zero, the chartplotter will remain On.

2.1.3. Auto power On Description

If you power Off the chartplotter during the normal working using an accessory switch (not pushing the **PWR** button), then the chartplotter will power On automatically when that same switch is turned back On.

2.2. INITIAL SETUP

Initial power on settings page that asks the user to input crucial setup information. The **FIRST TIME - GPS SETUP Page** appears at power On after the Logo Screen.

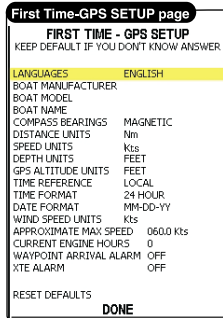

2.2.1. Definitions of Selections

This menu allows you to select some of the basic setup information the first time the chartplotter is powered On. This information can be changed at any time either from the **SYSTEM Page** (see Chapter 5) or by resetting the chartplotter. Select the correct setup option and select “**DONE**” and press the **ENTER** button when complete. Please refer to section 1.2 for more information on how to enter information.

- “**LANGUAGES**” - Selects the language in which you wish information to be displayed (for screen labels, menus and options, but it does not affect the map information).
- “**BOAT MANUFACTURER**” (**optional**) - Enters the boat manufacturers name to be displayed on the initial Logo Screen.
- “**BOAT MODEL**” (**optional**) - Enters the Model Name/Number of your boat to be displayed on the Logo Screen.
- “**BOAT NAME**” (**optional**) - Enters the boat name to be displayed on the Logo Screen.
- “**COMPASS BEARINGS**” - Selects either degrees magnetic or degrees true. If magnetic readings are selected the variation is computed automatically for every zone as soon as the chart is displayed.
- “**DISTANCE UNITS**” - Sets the distance unit among the available choices. The default setting is Nm (Nautical Miles). Other options are Statute Miles (Sm) and Kilometers (Km).
- “**SPEED UNITS**” - Sets the speed unit among the available units. The default setting is Knots (Nautical Miles/Hour). Other options are Miles per Hour (Mph) and Kilometers per Hour (Kph).
- “**DEPTH UNITS**” - Sets the depth units among the available units. The default setting is Ft (Feet). Other options are Meters (Mt) and Fathoms (Ft).
- “**GPS ALTITUDE UNITS**” - Sets the altitude of GPS Antenna on the



medium sea level unit among the available units. The default setting is Ft (Feet). Other options are Meters (Mt) and Flight Level (FL).

- **“TIME REFERENCE”** - Allows switching the Time Reference between UTC or Local. After entering the Local Time offset, your local time will be displayed. See Par. 5.2.6 for more detailed information.
- **“TIME FORMAT”** - Sets you preferred time format. The default setting is 24 hour time.
- **“DATE FORMAT”** - Sets you preferred date format between MM-DD-YY (month-day-year) and DD-MM-YY (day-month-year). The default setting is MM-DD-YY.
- **“WIND SPEED UNITS”** - Sets the Wind Speed units among the available units. The default setting is Knots (Nautical Miles/Hour). Other options are M/S, BFT, Miles per Hour (Mph) and Kilometers per Hour (Kph).
- **“APPROXIMATE MAX SPEED”** - This information will be used to set up the analog style speedometer gauge.
- **“CURRENT ENGINE HOURS” (optional)** - Starting value that will be used for the engine hours gauge.
- **“WAYPOINT ARRIVAL ALARM”** - Sets the distance you would like to have alarm sound when approaching a Waypoint.
- **“XTE ALARM”** - Sets the distance you go off course before an off course alarm will sound.
- **“RESET DEFAULTS”** - Changes all the settings on this page back to the original settings.

2.3. ADJUSTING THE BACKLIGHTING AND CONTRAST

You can change the level of backlight and contrast for the screen.

1. Press the **PWR** button. On the screen appears:

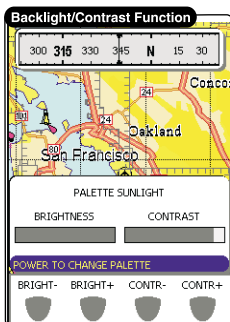

2. Use the software buttons to adjust the backlight and contrast levels.



- Wait or press the **ENTER** button to return to the chart screen with the new light levels retained.



NOTE

Continuously pressing the **PWR** button from this screen will toggle you through the available color palettes.

2.4. PAGE SURFING

There are many different pages of data and information available. You can select the page you wish “by surfing” among the available pages.

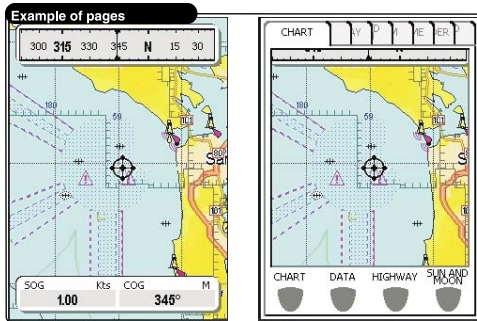

2.4.1. Pages selection

Pressing the **PAGE** button causes TABs to appear with the pages that you can scroll through. Continually pressing the **PAGE** button or the **RIGHT** and **LEFT CURSOR** buttons allow you to scroll forwards or backwards through the available pages. The TABs disappear after several seconds allowing you to resume full operation of the selected page.



NOTE

Please note that these available pages can be customized from the settings page (see Par. 3.1).



NOTE

The option of having the page TABs appear at the top of the page can be turned Off from the **SYSTEM Page** in the General settings menu.



2.5. DEMO MODE

DEMO MODE is great for practicing the actual use of a product when the satellites signals and internal alarms are not available. When the device is in **DEMO MODE**, the GPS receiver is turned Off, so it is impossible to navigate.



WARNING

Do not try to navigate in a **DEMO MODE**. While the **DEMO MODE** is turned On, the GPS receiver is not active. All satellite signal strength bars are only a simulation and do not indicate any actual satellite signals.

DEMO MODE can be selected from the **WELCOME Page** (see Par. 3.2) or from the **SYSTEM Page** (see Par. 5.2.9) .

Selecting the **DEMO MODE** would bring up the choice of three options for demo. The **DEMO MODES** are:

2.5.1. Full Demo

This mode is designed for in store or on display demonstration. This unit will automatically scroll through various displays and demonstrate the product.

2.5.2. Demo a Route

This mode allows the user to select a Route that they have already planned.

2.5.3. Custom Demo

This mode allows you to enter a desired course and speed for the demonstration. The simulated GPS position will start directly from the Pointers position on the chart.

2.6. MOVING AND ZOOMING ON CHART

Use the **CURSOR** buttons to move around or Pan the chart. Also use the **ZOOM IN** and **ZOOM OUT** buttons to change the chart scale so that a smaller or larger area is shown on the chart.

2.6.1. Pan

Controlled by the **CURSOR** buttons, the Pointer is an important tool that can be used to pan to other map locations, mark and edit Waypoints and Routes and review information about on-screen map items and Waypoints. Use the



map Pointer to pan away from your present position and scroll to other map areas even outside of your current detail coverage. While panning past the edge of the current map display, the screen actively scrolls forward to provide continuous map coverage.

2.6.2. Zoom

Zoom function is generally used to change a map scale and show relevant detail content.

- **ZOOM OUT** - Press the **ZOOM OUT** button to change the scale and show less details of a larger area.
- **ZOOM IN** – Press the **ZOOM IN** button to show more details of a smaller area.

2.6.3. Esc back to chart

The function of the **ESC** button is to come back to the **CHART Page** from every other page. The **ESC** button will also move back from a selection menu or to clear the screen.



NOTE

Please note that the **ESC** button is used to come back to original map Pointer location and a map scale after zooming and panning.

2.7. CHANGING DATA FIELDS ON MOST PAGES

It is possible to change the number of data fields shown at the bottom of most Pages. The number of fields and the value displayed in the field can be changed by selecting the **MAIN Menu** and then either the “**NUMBER OF DATA FIELDS**” or “**CHANGE DATA FIELDS**” option.

2.7.1. Number of Data Fields

Most pages give the ability to adjust the number of fields displayed on a given page. The available choices are predefined in the **MAIN Menu**. To change the number of data fields follow the procedure below:

1. Press the **MENU** button. The **MAIN Menu** will be activated.
2. Use the **UP** and **DOWN CURSOR** buttons to select the “**NUMBER OF DATA FIELDS**” option.
3. Press the **ENTER** button to access the available selections.
4. Use the **UP** and **DOWN CURSOR** buttons to select a desired choice.
5. Press the **ENTER** button to confirm, or the **ESC** button to abort and return to the previous settings.



2.7.2. Change Data Fields

Each data field present on a given page (no matter the number of data fields) can be customized to obtain the best navigational information.

1. Press the **MENU** button. The **MAIN Menu** will be activated.
2. Use the **UP** and **DOWN CURSOR** buttons to select the “**CHANGE DATA FIELDS**” option.
3. Press the **ENTER** button to confirm. A yellow frame appears around one of the data fields.
4. Use the **UP**, **DOWN**, **RIGHT** and **LEFT CURSOR** buttons to highlight and choose an individual data field.
5. Press the **ENTER** button to display the available data options for the chosen data field.
6. Use the **UP** and **DOWN CURSOR** buttons move through the options.
7. Press the **ENTER** button to select the on screen option or the **ESC** button to cancel and return to the previously selected data.



HINT

You can also complete this by holding the **MENU** button. This will place a yellow frame around one of the fields as per step 3 above.



Available Data Options Creating a User Point

Operation

2.7.3. Available Data Options

All the available choices for the Data Fields are presented in the table below. Keep in mind that some of them are characteristic only to one specified page. The yellow bar on the right will scroll down as you move down the list.

Available Data Fields
GPS SPEED
WATER SPEED
MAX SPEED
VMG TO WAYPOINT
TRIP LOG
TOTAL LOG
COURSE OVER GROUND (COG)
BEARING TO WAYPOINT (BRG)
CROSS TRACK ERROR (XTE)
DEPTH
WATER TEMP
AUX TEMP
DISTANCE TO NEXT (DTN)
TIME TO NEXT (TTN)
DISTANCE TO DESTINATION (DTD)
TIME TO GO (TTG)
ESTIMATED TIME OF ARRIVAL (ETA)
LATITUDE
LONGITUDE
BATTERY VOLTAGE
ENGINE HOURS
TRUE WIND SPEED (WST)
TRUE WIND DIRECTION (WDT)
APPARENT WIND SPEED (WSA)
APPARENT WIND DIRECTION (WDA)
VMG TO WIND
CHART SCALE
FIX STATUS
VDOP
NUMBER OF SATELLITES (SAT)
HDOP
TIME
DATE
GPS ALTITUDE (ALT)
RMODE

2.8. CREATING A USER POINT

A User Point is an object that you can place on the charts to mark a specific point. The chartplotter features two types of User Points: Marks and Waypoints.

2.8.1. Creating a New Waypoint



A Waypoint is created when entering a Route:

1. Move the Pointer to the desired location on the chart.
2. Press the **ENTER** button.
3. Use the **UP** or **DOWN CURSOR** button to select “**NEW WAYPOINT**” and press the **ENTER** button. The new Waypoint is placed.



4. Move the Pointer off the location to accept.

2.8.2. Creating a New Mark



A Mark can be created at anytime. Marks are used for marking points outside of a Route.

1. Move the Pointer to the desired location on the chart.
2. Press the **ENTER** button.
3. Use the **UP** or **DOWN CURSOR** button to select “**NEW MARK**” and press the **ENTER** button. The new Mark appears on your Pointer.
4. Move the Pointer off the location to accept.

NOTE

You can also use the shortcut software buttons that appear when moving the Pointer. See the following picture:

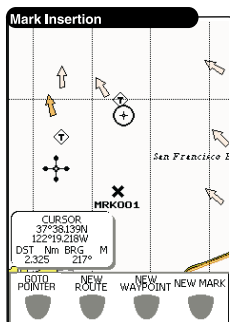

2.9. CREATING A BASIC ROUTE

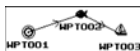

To create a Route:

1. Move the Pointer to the desired location on the chart.
2. Press the **ENTER** button.
3. Use the **UP** or **DOWN CURSOR** button to select “**NEW WAYPOINT**” and press the **ENTER** button. This places the first Waypoint of the new Route on your Pointer position. To place the next Waypoints of the Route repeat the above procedure.
4. Move the Pointer off the location to accept or press the **ENTER** button to edit.



2.10. USING GOTO

The **GOTO** function allows instant plotting of course to selected target. After pressing the **GOTO** button on most of the pages, the sub-menu on a Pointer position appears and it is possible to choose beneath mentioned options:



- **“GOTO POINTER”** - Sets the Pointer location as the destination.
- **“GOTO POINT”** - Shows the “User Point” list, that gives information on all stored User Points.
- **“FOLLOW ROUTE”** - Brings up the “Select Route” list with the most recently used highlighted.
- **“NEW ROUTE”** - Brings up the “Selected Route” list but with the next open Route highlighted. Software button choices are: **EDIT**, **ACCEPT**.
- **“NEW WAYPOINT”** - A new Waypoint is created and set as the destination Waypoint.
- **“NEW MARK”** - A new Mark is created.
- **“MOB”** - Man OverBoard (MOB) function. See Par. 2.12 for details.
- **“FIND”** - Find function. See Par. 2.11 for details.

2.11. USING FIND

The Find function allows searching for the nearest Ports, Port Services, Tide Stations, Wrecks, Obstructions loaded on the C-CARD or it centers the screen over a selected User Point or at desired Coordinates. When you press the **FIND** button (or choose Find from a menu option) a list of available objects to search is shown.



NOTE

A Warning message is shown when activating the Find function if no C-CARD inserted.



2.12. USING MOB

If a person or object is lost overboard and you need to return to the location, use the MOB (Man OverBoard) function. This function enables you to simultaneously mark and set a course to a location for quick response to emergency situations.



NOTE

To activate the MOB function, a valid GPS fix must be available.

2.12.1. Inserting MOB



To activate a MOB function follow the procedure below:

1. Press the **MOB** button. A dialog box with a message “MOB is activated” will appear on a screen and a MOB Waypoint will be created.
2. If the NMEA output is turned On, the warning dialog box is given: “Turn off autopilot before setting MOB point as destination”

2.12.2. Deleting MOB

To cancel the MOB function

1. Use the **CURSOR** button to move the Pointer over the MOB icon.
2. Choose the **DELETE** or **STOP NAV** software buttons at the bottom of the display.



3. PAGE INFORMATION AND OPERATION

3.1. PAGE SELECTION AND PRESETS - SETUP

Any page can be turned ON or OFF using the following procedure:

1. Press the **PAGE** button several times to select “**SYSTEM**” and then press the **ENTER** button.
2. Use the **UP** and **DOWN CURSOR** buttons to select the “**PAGES ON/OFF**” option and then press the **ENTER** button.

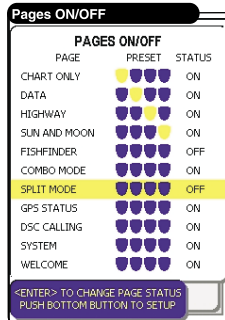

3. Press the **ENTER** button to change the page status (On or Off).
4. Press one of the bottom software buttons to assign it as a short cut to the desired page. The **RIGHT** and **LEFT CURSOR** buttons can also be used to change the selection if the page has already been assigned a button.

During future operations the ON pages can be selected using the **PAGE** button which is generally used to scroll through all available pages.



NOTE

Pages containing certain data like the Fish Finder and Combo are not accessible unless that optional module is connected.



NOTE

Press and hold one of the software buttons from any of the main pages to save that as one of quick access pages.



3.2. WELCOME PAGE

The **WELCOME Page** is activated by default on Power On and appears after the GPS position lock. Use the **WELCOME Page** to go to the most commonly-used features on the chartplotter that are otherwise more difficult to access. All of the options in these large selection boxes are also available from other pages and selections.

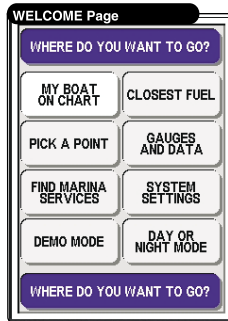

3.2.1. Operations

The **CURSOR** buttons are used to choose an individual feature box. Press the **ENTER** button to display the available feature's options. After selection use the **PAGE** button to return to the **WELCOME Page**. 8 different options are available from this page:

- **“MY BOAT ON CHART”**: Goes back to the **CHART Page**, centered on the vessel's position.
- **“CLOSEST FUEL”**: Goes right to the list of closest Fuel Stations with distance and bearing listed.
- **“PICK A POINT”**: Goes to the predefined User Point list with the closest point highlighted.
- **“GAUGES AND DATA”**: Goes to the **DATA Page**.
- **“FIND MARINE SERVICES”**: Shows an icon selection table. Use the **CURSOR** button to highlight an icon. A description of the type of service is listed. Press the **ENTER** button to search for this type of service.
- **“SYSTEM SETTINGS”**: Goes directly to the **SYSTEM Page** for setup info.



NOTE

The **System Page** can also be accessed by pressing the **MENU** button twice from most pages.



- **“DEMO MODE”**: Links to a secondary set of selection boxes. The DEMO Mode is specified in further detail in Par. 2.5.
- **“DAY OR NIGHTWATCH™ MODE”**: Selection toggles between Day and Nightwatch™ depending on what mode the display is in at the time of selection.



NOTE

The screen will be difficult to read if the chartplotter is in Nightwatch™ mode and the sun is to bright. With the chartplotter on, continuously pressing the **PWR** button will get the chartplotter out of Nightwatch™ mode.



3.3. CHART ONLY PAGE



The **CHART Page** is the main page of the chartplotter. From this page the user can select the desired map, get information about cartographic objects on the maps, see the vessel position, its direction and speed, place points (Marks, Waypoints), set a destination point and display additional features. The chartplotter is provided with worldwide background cartography while the detailed charts of the desired area are available on data cartridges.

3.3.1. Description

The picture below shows the **CHART Page** layout with displayed data fields and a steering compass added at the top. It is possible to customize all fields shown in the page as described later in this paragraph. The central section of the screen provides visual guidance of a chart and the bottom of the page is designed for navigation data display.

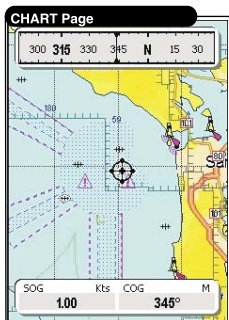

3.3.2. Operations

The **CHART Page** is used for display of electronic cartography, creating and using the User Points, plotting position and navigational data.

3.3.2.1. Available Layouts of CHART Page

The data fields of the **CHART Page** can be customized as HIDE, 2, 4 or 6 through the **MENU** button. By default the **CHART Page** is specified for 2 data fields and a Steering Compass added over a Horizon. The Compass can be turned Off in the Main Menu of the **CHART Page** by pressing the **MENU** button.

3.3.2.2. Changing Data Options

The content of each data field can be adjusted to the user's requirements. To customize data options follow the procedure described in Par. 2.7.2 Changing Data Fields.



3.3.2.3. Operations on User Points

Using the **ENTER** button we are able to create, edit and delete various User Points used during further navigation. Those advanced operations are explained in detail in Chapter 4.

3.3.2.4. Software Buttons

The functional software buttons are activated when moving the Pointer with the **CURSOR** buttons. They acts as a shortcuts for the **GOTO** functions including: **Go To POINTER**, **NEW ROUTE**, **NEW WAYPOINT**, and **NEW MARK**. These functions time out after several seconds. The **ESC** button disables these software buttons for several more seconds.



3.3.3. Menu

The **MAIN Menu** (selected through the **MENU** button) of the **CHART Page** provides the operations for the chart display.

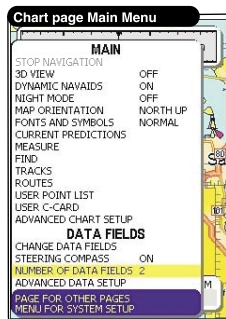

NOTE

Some of the more commonly accessed features are listed first.



MAIN

- **“STOP NAVIGATION”**: Stops navigation to destination, if Target is set.
- **“3D VIEW”**: Changes from standard to 3D mode. This could also be used to choose viewing angle.
- **“DYNAMIC NAV AIDS”**: Turns ON or OFF the blinking lights on Nav-Aids.
- **“NIGHT MODE”**: Toggles the color setting in color pallets directly between the current daytime color pallet and night mode.
- **“MAP ORIENTATION”**: Selects the orientation of your chart according to: North Up (the map is shown with North upwards), Heading Up (the map is shown with the ship's current heading upwards), Course Up (the map is displayed with the currently selected course leg upwards).
- **“FONTS AND SYMBOLS”**: On MAX charts it is possible to set the size of all names and symbols drawn on the charts, selecting between Normal size (the regular characters size) and Large size.
- **“CURRENT PREDICTIONS”**: Shows the variation of the Tidal arrows on the selected area at any given time. See also Par. 4.8
- **“MEASURE”**: Allows measuring Distance and Bearing between two points on the **CHART Page**. See also Par. 4.1.
- **“FIND”**: The same as pushing the Find button. See Par. 2.11.
- **“TRACKS”**: Allows the management of the Track. See also Par. 4.4.
- **“ROUTES”**: Allows the management of the Route. See also Par. 4.3.
- **“USER POINTS LIST”**: Selects the User Points List Page with information on all stored User Points. See also Par. 4.6.
- **“USER C-CARD”**: Allows the management of the User C-CARD . See also Par. 4.6.
- **“ADVANCED CHART SETUP”**: Goes directly to the System Menu and into the Chart Settings.

DATA FIELDS

- **“CHANGE DATA FIELD”**: Any data field can be highlighted and changed to any available data option.
- **“STEERING COMPASS”**: Enables or disables the display of the Steering Compass in the top of the **CHART Page**.
- **“NUMBER OF DATA FIELDS”**: Sets the number of fields displayed on the **CHART Page**.
- **“ADVANCED DATA SETUP”**: Goes directly to the System Menu and into the Units menu.



NOTE

The **ESC** button always bring you to the center of the chart.



3.4. DATA PAGE

Use the **DATA Page** to customize the data options described below.

3.4.1. Description

The pictures below present the available **DATA Page** layouts with respect to displayed data fields.

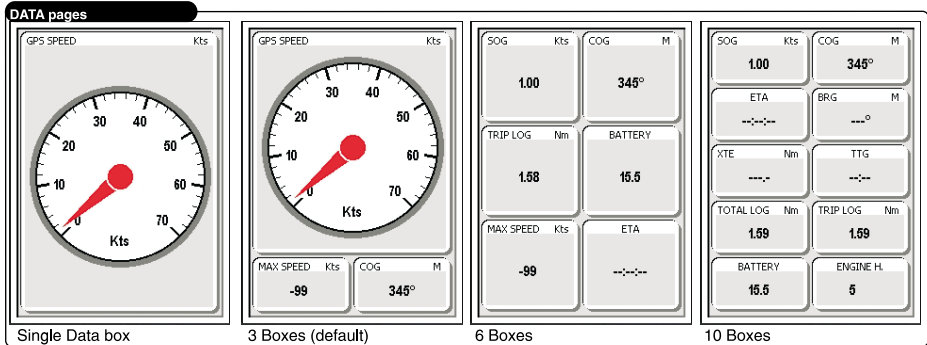

3.4.2. Operations

The main feature of the **DATA Page** is the ability to customize all data options according to a user's requirements.

3.4.2.1. Available Layouts of DATA Page

The choice for the number of fields is 1,3,6 or 10, and field values can be configured by pressing the **RIGHT** or **LEFT CURSOR** button located on the right side panel. The default page is the "3 Boxes" page with the Analogue-Style Speedometer Gauge.

3.4.2.2. Changing Data Options

The content of each data field can be adjusted to user's requirements. To customize data options follow the procedure described in Par. 2.7.2 Changing Data Fields. The default "Speed Gauge" data field can be also changed into an "Analogue-Style Compass".



NOTE

Please note that some of the data options can be grayed out if unavailable. This can be caused by NMEA data unavailable to support the data field or items related to Fish Finder when not connected.



3.4.2.3. On Screen Instructions

When first arriving at the page or after pressing the **ENTER** button, Screen Instructions will appear at the top of the page. The Screen Instructions are On by default and disappear after a few seconds.



NOTE

This option can be turned OFF for more advanced users.

3.4.3. Menu

Pressing the **MENU** button while displaying the **DATA Page** shows not only some standard menu options available from other pages like Stop Navigation, Find and Night Mode, but it also shows some options unique to the **DATA Page** such as Reset Trip Log, Reset Total Log, Reset Maximum Speed, Screen Instructions and Data Field tools. Press the **ENTER** button to accept any selected menu option or the **ESC** button to cancel your choice.

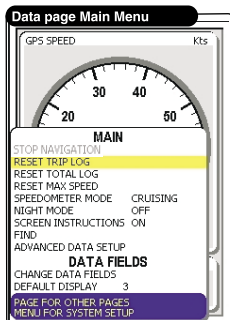

- **“RESET TRIP LOG”**: Resets the distance traveled since it was last reset.
- **“RESET TOTAL LOG”**: Clears the total traveled distance.
- **“RESET MAX SPEED”**: Resets the highest boat speed measured since the Speed Log was switched On.
- **“SPEEDOMETER MODE”**: Customizes the Analog speedometer gauge for maximum performance based on the selected value. The best resolution is given for the target speed of the chosen activity. The top speed is determined from the initial setup page and can be changed in the future from the About section in the **SYSTEM Page**.



- **“SCREEN INSTRUCTIONS”** at the top of the page are ON by default. This option allows the users to turn OFF these Screen Instructions once they are familiar with the features.
- **“DEFAULT DISPLAY”**: Changes the **DATA Page** that is the first displayed. Default page layout is set to 3 fields with the Analogue GPS Speed shown.



3.5. HIGHWAY PAGE



Whenever it is activated the **HIGHWAY Page** uses the most relevant navigation information to provide digital and graphical steering guidance to the destination.

3.5.1. Description

The picture below shows the layout of the **HIGHWAY Page** with 4 data fields and a steering compass above the Horizon. The data fields and steering compass are shown by default. It is possible to customize all fields shown in the **HIGHWAY Page**, as described later in this section. The central section of the screen provides visual guidance to the Waypoint on a graphical “highway display”, and the bottom of the page is designed for navigation data display. The line down the center of the highway represents the desired track line.

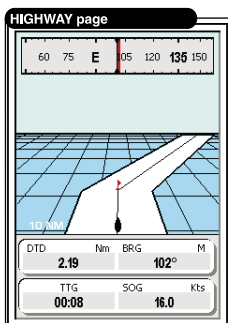

NOTE

The distance between a vessel and a Target can be changed using the **ZOOM IN** and **ZOOM OUT** buttons. The distance from the center line to the side of the highway is indicated on the display.

As a vessel heads towards its destination, the highway perspective moves to indicate progress to the Waypoint and the proper direction which should be kept to stay on course. If a navigation Route is defined, the **HIGHWAY Page** shows each Waypoint of the Route in sequence. “Clouds” are shown during the day and “Stars” for when night mode is set.

3.5.2. Operations

The **HIGHWAY Page** provides access to functions and features using the **MENU** button and software button options.



3.5.2.1. Available Layouts of HIGHWAY Page

The data fields of the **HIGHWAY Page** can be customized to HIDE, 2 or 4 through the **MENU** button. By default the **HIGHWAY Page** is specified for 4 data fields and a Steering Compass added over the Horizon. It is possible to customize all data fields according to the user's requirements. To customize data options follow the procedure described in Par. 2.7.2 Changing Data Fields.

3.5.2.2. ZOOM IN AND ZOOM OUT

The highway perspective range can be zoomed in or out to display a larger or smaller view of a highway.

- **ZOOM OUT** - Press **ZOOM OUT** button to change the scale and show a wider, less detailed view. The distance from the center line to either side of the highway will change from 0.2 -> 0.5 -> 1.0 -> 2.0 -> 4.0 -> 10.0.
- **ZOOM IN** - Press the **ZOOM IN** to show a narrower, more detailed view.

3.5.3. Menu

The **MAIN Menu** of the **HIGHWAY Page** provides the same operations as the **CHART Page** display but it also provides some of access to various options and features related to the **HIGHWAY Page**.

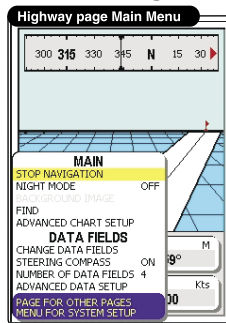

- **“BACKGROUND IMAGE”**: Allows the user to turn OFF the image ('Clouds' or 'Stars') and show a blue background instead.
- **“STEERING COMPASS”**: Turns ON or OFF display of the compass above the Horizon.
- **“NUMBER OF DATA FIELDS”**: Changes the **HIGHWAY Page** layout; it can be set to 2, 4 or HIDE data fields.



Sun and Moon Page

Operation

3.6. SUN AND MOON PAGE



The **SUN and MOON Page** presents a graphical chart that displays Tide station information in a 24-hour span starting at midnight. The choice of different dates and various Tide Stations all around the world is available.

NOTE

Tide data shown on this page comes from an optional C-CARD data.

3.6.1. Description - “Telling” Tide

The picture below presents a layout of the **SUN and MOON Page** with 8 data fields set by default and a graph showing Tide information from a given Tide station. The highest Tides are represented by the top of the curve and the lowest Tides by the bottom of the curve.

NOTE

Tide heights are indicated at height of Tide above the mean low Tide.

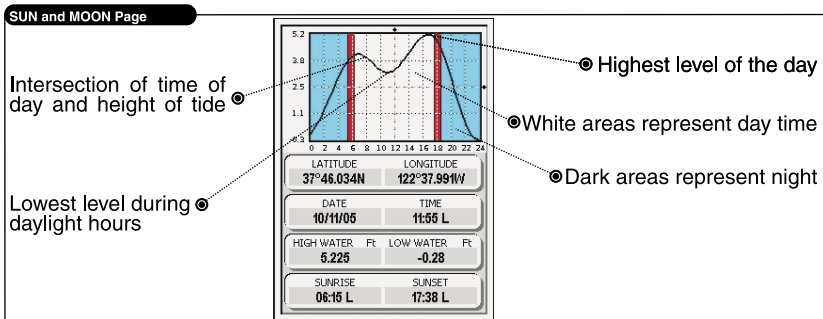

- **“LATITUDE/LONGITUDE”**: Location of the Tide symbol/station on the chart.
- **“DATE/TIME”**: Date and Time of the indicated data.
- **“HIGH WATER/LOW WATER”**: The highest and lowest Tide heights of the day.
- **“SUNRISE/SUNSET”**: Time of day for sunrise and sunset.

3.6.2. Operations

The **SUN and MOON Page** provides Tide Info with relevance to desired Tide Station and Location.



3.6.2.1. Available Layouts of SUN and MOON Page.

There is no possibility to change either the number of data fields nor their content. The default number of fields is 8 including: Latitude, Longitude, High Water Level, Low Water Level, Sunrise, Sunset, Date and Time.

3.6.2.2. Finding the Nearest Tide Stations

Tides are measured and predicted relative to local Tide Station. To select the Nearest Tide Station from a current location follow the procedure below:

1. Press the **MENU** button to open the **MAIN Menu** of the **SUN and MOON Page**.
2. Use the **CURSOR** buttons to select “**FIND CLOSEST STATIONS**” option and press the **ENTER** button
3. The list of the Nearest Tide Stations, their names, distance from current position and bearing will appear. Highlight your selection with the **CURSOR** buttons, and press the **ENTER** button.

The result of your selection will be visible on a graph. If there is no available Tide Station in the nearest area, the message appears. If necessary, use the Pointer to select a location closer to a Tide Station and use the FIND feature to find the closest station.

3.6.2.3. Finding a Tide Station on a map

Using the **MENU** button you can activate the Find option (also you can use the **FIND** button).

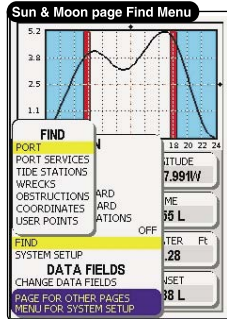

1. Press the **MENU** button to open the **MAIN Menu** of the **SUN and MOON Page**.
2. Use the **CURSOR** buttons to select “**FIND**” option and press the **ENTER** button (or just press the **FIND** button)
3. The list of individual options appears. Highlight the **Tide Station** option with the **CURSOR** buttons, and press the **ENTER** button.
4. A list of Tide Stations will appear. Use the **CURSOR** buttons and the **ENTER** button to choose a desired item and locate it on a chart.



The result of your selection will be visible on a chart. An error message will appear if there are no Tide Stations in the immediate area. Use the Pointer to select a location closer to a Tide Station.

3.6.2.4. Changing the date for the Tide Chart

You can also change the date to see Tide charts for other days, or move the time bar in approximately five (5) minutes increments to display Tide heights at various times. To change the date for the Tide height follow the procedure below:

1. Press the **MENU** button to open the **MAIN Menu** of the **SUN and MOON Page**.
2. Use the **CURSOR** buttons to select the “**SET DATE**” option and press the **ENTER** button. Set and save the desired date and the tidal information for that day will be displayed.

There is also a possibility to see Tide Info for the **NEXT DAY** or **PREVIOUS DAY** using the options from the **MAIN Menu**.

3.6.2.5. Various Animation Options

Using the **MAIN Menu** it is possible to activate two additional options able to animate the Tide info using some future predictions concerning time and date.

- **PLAY TIME FORWARD** - Runs the vertical line along the X-Axis horizontally at a rate of 0.75 Hours/Second. A vertical line travels up and down on the Y-axis following the intersection of the curve. When the day comes to an end then the date advances and it continues on the same curve.
- **PLAY DATE FORWARD** - Jumps from the current date to the next day at a rate of 1 Day every 2 seconds. The X and Y axis stay stationary at the set time of day.

To initialize above functions follow the procedure below:

1. Press the **MENU** button to open the **MAIN Menu** of the **SUN and MOON Page**.
2. Use the **CURSOR** buttons to select one of the above mentioned options and press the **ENTER** button. The function will be activated and the result will be shown on a graph. Press the **ESC** button to stop the animation at any time.



NOTE

You can also use the **ZOOM OUT** button to go back one (1) day, the **ZOOM IN** button to go forward one (1) day.



3.7. FISH FINDER PAGE



The **FISH FINDER Page** appears only when the Fish Finder device is available or a Demo Mode is active. The Fish Finder monitors the water column and delivers valuable information about school of fish and bottom structure. To see this information, make sure that an optional Fish Finder device is installed and connected properly. See your CobraMarine™ Black Box Fish Finder Owner's Manual for complete installation instructions.

3.7.1. Description

The picture below shows the **FISH FINDER Page** layout with no data fields shown. It is possible to customize the number of data fields. This page contains a right-to-left moving sonar image of the water column beneath the Fish Finder sensor.

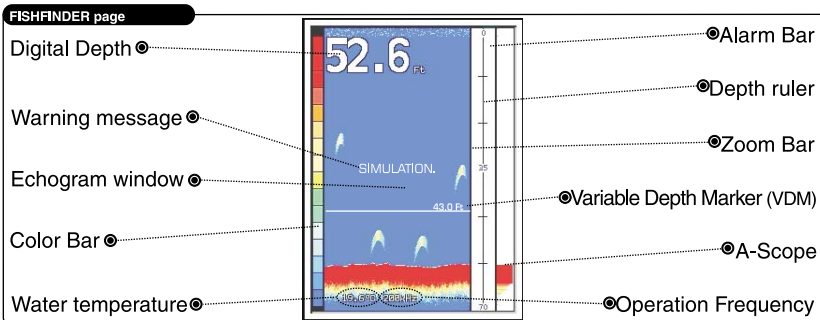

The most recent items passing under the transducer are displayed on the right side of the screen. The scale which is visible on the right side of the screen indicates the depth of the area which is being currently displayed from the top to the bottom of the screen. The top left corner is dedicated for the depth information. Temperature of the water and the frequency is displayed on the bottom of the page.

The following is a short description of terms listed in the previous picture:

- **Warning Message**
Flashing label "Simulation" when the echo sounder is in Demo mode.
- **Echogram window**
Graphic presentation of sonar soundings recorded as a continuous profile scrolling across the screen from right to left. Such recordings represent the image of the water beneath your boat, items appear as they pass under



your transducer; the items on the right side of the screen are closer to you than those on the left. The correct interpretation of the Echogram allows retrieving useful information about what is under the boat. See the following Par. 3.7.1.1 for more information.

- **Color Bar**
Colored scale located on the left side of the screen that shows the colors used in the Echogram to represent the echoes strength. The color on the top of the bar represents the maximum sonar strength, while the color on the bottom of the bar represents the minimum sonar strength. It shows red (the strongest), orange (strong), yellow (medium), green (weaker), and blue (the weakest).
- **Digital Depth**
Readout of the current bottom depth.
- **Water Temperature**
Readout of the current water temperature returned by the TEMP 1 sensor included into specific transducers.
- **Alarm Bar**
Bars showing the shallow water and deep water alarm values. The alarm is triggered when depth is outside the range.
- **Depth ruler**
Vertical graduated bar. It is a scale which reflects the depth of the area being displayed.
- **Variable Depth Marker (VDM)**
Horizontal line on to the Echogram window with a depth label. The up/down cursor buttons can move it up and down. The label displays the depth of the cursor position. It can be moved to any location pinpointing the depth of a target.
- **Zoom Bar**
Bar showing the portion of the Echogram currently represented in the zoomed window (on the left part of the screen). It is turned on selecting Zoom Full display page.
- **A-Scope**
A real time representation of fish and bottom features passing through the beam of the transducer. It is drawn as horizontal lines whose length and hue is proportional to the sonar strength returned. When the default palette is selected, the strongest sonar returns will be shown as the color displayed of the top of Color Bar while the weakest as the bottom color. This feature is useful for close observation of small fish and fish near the bottom.
- **Operating Frequency**
Readout of the selected operating frequency.



3.7.1.1. Understanding the Fish Finder Echogram

The main elements that can be easily distinguished into an Echogram are:

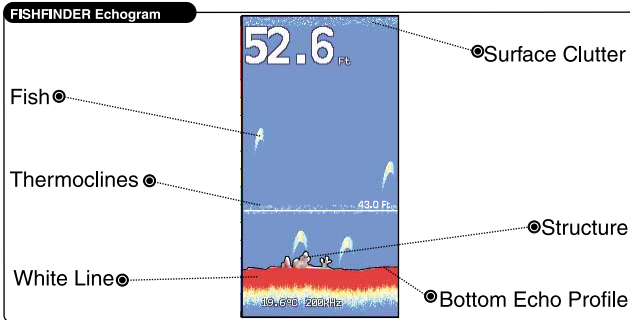

■ Fish

Fish is represented as arc because of the cone angle of the transducer. In fact as the boat passes over the fish the leading edge of the cone strikes the fish, causing a display pixel to be turned on. As the boat passes over the fish, the distance to the fish decreases turning each pixel on at a shallower depth on the display. When the boat is directly over the fish, the first half of the arch is formed and since the fish is closer to the boat, the signal is stronger and the arch is thicker. As the boat moves away from the fish, the distance increases and the pixels appear at progressively deeper depths forming the remaining half of the arch. The **FISH SYMBOL** option, found after pressing the **MENU** button, enables to set the actual sonar data, fish symbols, or a combination of both. After changing the Frequency of a sonar signal the graphical presentation of items may change slightly.

■ Thermoclines

Are the zones where two layers of different water temperatures meet. The greater the temperature differential, the thicker the thermocline is shown on the screen. Thermoclines are represented as horizontal stripes of noise. They are very important for fishing since often many species of game fish like to suspend in, just above, or just below the thermoclines.

■ White Line

The White Line shows the difference between hard, soft bottoms and even distinguishes between fish and structures located near the bottom. In this way it is easier to tell the difference between a hard and soft bottom and even to distinguish fish and structures located nearby the bottom. For example, a soft, muddy or weedy bottom returns a weaker echo that is shown with a narrow white line while a hard bottom returns a strong echo that causes a wide white bottom line.



■ **Surface Clutter**

Appears like noise at the top of the screen extending many feet below the surface. It's caused by many things, including air bubbles, bait fish, plankton and algae.

■ **Structure**

Generally, the term "structure" is used to identify objects like wrecks and weeds rising from the bottom.

■ **Bottom Echo Profile**

Bottom profile recorded by the Fish Finder. When the echo sounder is set in autorange mode it is automatically kept in the lower half of the screen.

Other Elements

Large anchoring cables are returned by the echo sounder as very long and narrow arcs on the screen.

3.7.2. Operations

The **FISH FINDER Page** provides the access to information delivered by the optional external Fish Finder device. Access to most of the options for the **FISH FINDER Page** are available via the **MAIN Menu**.

3.7.2.1. Available Layouts of FISH FINDER Page

The data fields of the **FISH FINDER Page** can be customized to HIDE, 2, 4 or 6 through the **MENU** button. By default the **FISH FINDER Page** is specified for 2 data fields.

3.7.2.2. Changing Data Options

The content of each data box can be adjusted to user's requirements. To customize data options follow the procedure described in Par. 2.7.2 Changing Data Fields.

3.7.2.3. Split Mode of the FISH FINDER Page

You can set the **FISH FINDER Page** display to show a split screen view of the zoomed portion of sonar options. For details see Par. 3.9.

3.7.3. Menu

Use the **MENU** button to show the **MAIN Menu** which contains options and functions characteristic for the **FISH FINDER Page**.

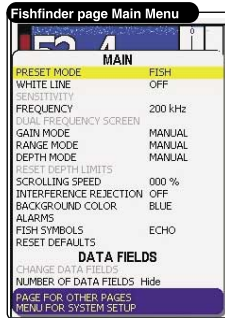

- **“PRESET MODE”**: Applies the Fish Finder operating mode presets.
- **“WHITE LINE”**: Used to monitor how the Fish Finder device displays information about the nature of a bottom (soft or hard). The thin White Line indicates a softer bottom whereas a thick White Line indicates a harder bottom. When this function is set for “OFF”, the bottom return displays as red and contains no information on bottom hardness.
- **“SENSITIVITY”**: Quick Access to some of the most commonly used controls for Fish Finder performance.
- **“FREQUENCY”**: Changes the frequency of a sonar signal between 50kHz and 200 kHz, providing optimal bottom and fish detection in both shallow and deep water. Each frequency can be displayed individually in full screen mode, or simultaneously in dual frequency mode.
- **“DUAL FREQUENCY SCREEN”**: Divides the screen to show the 50 Khz images on one side and the 200 Khz images on the other side.
- **“GAIN MODE”**: Controls the sensitivity of the unit’s receiver, which provides some flexibility in the display. To see more details increase the receiver sensitivity by selecting a higher gain percentage. To decrease the rate of details, select a lower gain percentage.
- **“RANGE MODE”**: Selects the range options.
- **“DEPTH MODE”**: Selects the depth options.
- **“RESET DEPTH LIMITS”**: Allows the user to eliminate the Depth Limits and start viewing the full or specified depth range.
- **“SCROLLING SPEED”**: Adjusts the chart scrolling rate. Note that the scrolling rate is limited by the sound speed and the depth with the following relation: the deeper the setting, the slower the scrolling rate. 100% is the maximum possible.
- **“INTERFERENCE REJECTION”**: Enables a filter to remove interference from other Fish Finders.
- **“BACKGROUND COLOR”**: Changes the color scheme of the Fish Finder



display. This selection is a personal preference. Select the option that gives you the clearest viewing in your weather conditions and viewing angle.

- **“ALARMS”**: Opens the **Alarm Settings** for Fish Finders within the System Menu. A full description of these alarms is in Par. 5.2.5.3.
- **“FISH SYMBOLS”**: Graphical representation of underwater suspended targets. Several options are available including the option to show the depth of each Target.
- **“RESET DEFAULTS”**: Resets the default Fish Finder setting and tuning adjustments.



NOTE

Zoom In and Zoom Out will zoom in on the bottom or on a selected depth if you use the **CURSOR UP** or **CURSOR DOWN** button to select a depth.



NOTE

The **CURSOR UP** or **CURSOR DOWN** button allows you to set depth upper and lower units. This create a depth “window” and gives you better resolution of Targets at the specified depth.



Combo Mode Page

Operation

3.8. COMBO MODE PAGE



The **COMBO MODE Page** allows you to set vertical and horizontal combo screens to display **CHART** and **FISH FINDER Pages** simultaneously.

3.8.1. Description

The pictures below represent different combinations of displayed combo screens. Each configuration can be activated from the **MAIN Menu** after pressing the **MENU** button.

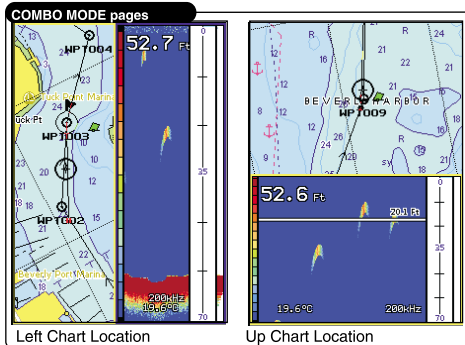

NOTE

The yellow box surrounds the area of the screen that is active. Press and hold the **PAGE** button to change the yellow box from the Chart window to the Fish window.

3.8.2. Operations

3.8.2.1. Moving the location of the Chart Window

It is possible to set the **CHART Page** view in 4 different locations: Left, Right, Up or Down. To customize the **COMBO MODE Page** follow the procedure:

1. Press the **MENU** button to activate the **MAIN Menu**.
2. Use the **UP** and **DOWN CURSOR** buttons to select “**CHART LOCATION**” option.
3. Press the **ENTER** button to view all the available choices: “**LEFT**”, “**RIGHT**”, “**UP**” or “**DOWN**”.
4. Use the **UP** and **DOWN CURSOR** buttons to select a desired Chart Location.
5. Press the **ENTER** button to confirm.
6. Press the **ESC** button to save the selection and go back to the **COMBO MODE Page**.



3.8.2.2. Available Layouts of COMBO MODE Page

The data fields in the **COMBO MODE Page** are the same as in the **SPLIT MODE Page** and can be customized to HIDE, 2 or 4 through the **MENU** button. By default the **COMBO MODE** is set to Hide data fields.

3.8.2.3 Changing Data Options

The content of each data box can be adjusted to user's requirements. To customize data options follow the procedure described in Par. 2.7.2 Changing Data Fields.

3.8.2.4. Changing the Size of Windows

It is possible to change the ratio for the two displayed combo screen by changing the size of each of them or both simultaneously. To activate this option follow the procedure below:

1. Press the **MENU** button to activate the **MAIN Menu**.
2. Use the **UP** and **DOWN CURSOR** buttons to highlight "**ADJUST SPLIT**" and press the **ENTER** button.
3. A yellow line is shown indicating the ability to drag the boundary of each separate page. Also the arrow icons indicating the available directions to move the line will be visible.
4. In case of vertical combo screens: Left and Right arrow icons will appear. Use the **RIGHT** and **LEFT CURSOR** buttons to change the ratio between pages. Press the **ENTER** button to save the changes and leave the Adjust Split Mode.

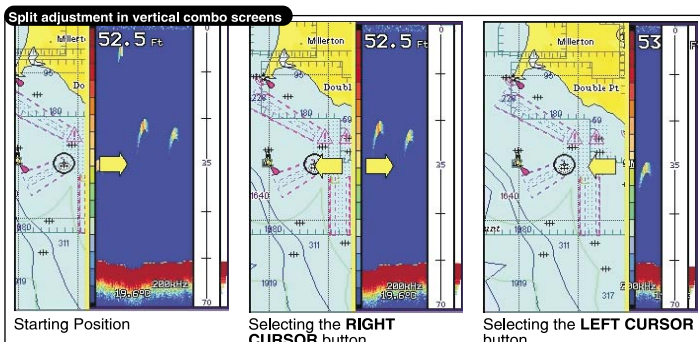

5. In case of horizontal combo screens: Up and Down arrow icons will appear. Use the **UP** and **DOWN CURSOR** buttons to change the ratio between pages. Press the **ENTER** button to save the changes and leave the Adjust Split Mode.



NOTE

Press and hold the **ENTER** button for more than one (1) second to quickly enter the Adjust Split option.



NOTE

Adjust Split option will change the ratio for the two displayed Combo screens by approximately 1/3rd and 2/3rd of the screen. When changing the height of the water column, the history of the Fish Finder will be lost.

3.8.3. Screen Control

The choice for Screen Control toggles the active window between the **CHART Page** and the **FISH FINDER Page**.

To activate a desired window follow the procedure below:

1. Select the “**SCREEN CONTROL**” option from the **MAIN Menu**.
2. Use the **CURSOR** buttons to activate a desired window. The active window will be highlighted in yellow.
3. Press the **ENTER** buttons to confirm your selection.

After page activation both the functions of hardware buttons and **Menu** options correspond to their functions on a given page. Pressing the **MENU** button brings up the appropriate menu for the area which is highlighted and enables all relevant page functions.



NOTE

Press and hold the **PAGE** button for more than one (1) second to change the Screen Control.



NOTE

See the separate **CHART Page** and **FISH FINDER Page** selections of the Owner's Manual for detailed operation of each page.



3.9. SPLIT MODE PAGE

Vertical and horizontal split screens allows for 2 display modes to be displayed simultaneously. This page can be used with or without the optional CobraMarine™ Fish Finder connected.

3.9.1. Description

These are some examples of available split mode options. These and more configuration options can be activated from the **MAIN Menu** after pressing the **MENU** button. Examples:

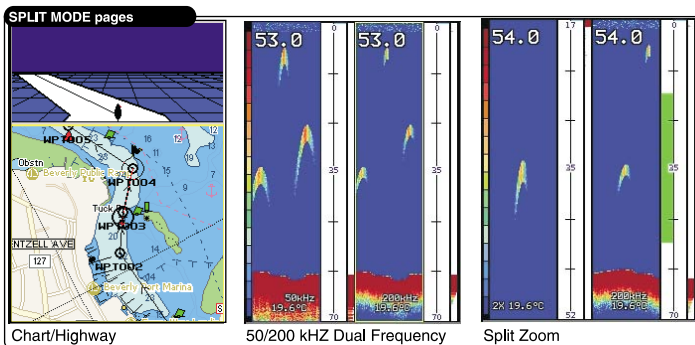

- **“CHART/HIGHWAY”**: A combination with the **CHART Page** and the **HIGHWAY Page** is possible. It delivers chart options and the most relevant navigation information to provide digital and graphical steering guidance to the destination. The default setting is Chart on a bottom and Highway on top.
- **“50/200”**: This mode combines both frequencies (50 and 200kHz) to get the best coverage area and depths readings. By default, the 50 kHz window displayed on the left and the 200 kHz window on the right.
- **“SPLIT ZOOM”**: It is possible to set the display to show a split screen view. One side will show a zoom portion of the sonar, split frequencies, bottom lock or a combination of those options. The default setting is standard Fish Finder page on the right, and Zoom on the left.

3.9.1.1. Available Layouts of SLIT MODE Page

The data fields in the **SPLIT MODE Page** can be customized to HIDE, 2 or 4 through the **MENU** button.

3.9.1.2. Changing Data Options

The content of each data box can be adjusted to user’s requirements. To



customize data options follow the procedure described in Par. 2.7.2 Changing Data Fields.

3.9.1.3. Changing the size of windows

See Par. 3.8.2.4 in the **COMBO MODE Page** section for detailed function description.

3.9.1.4. Changing the Screen Control

The choice for Screen Control toggles the active window between the TOP, BOTTOM, RIGHT and LEFT.

To activate a desired window follow the procedure below:

1. Select the “**SCREEN CONTROL**” option from the **MAIN Menu** after pressing the **MENU** button.
2. Use the **CURSOR** buttons to choose a desired window.
3. Press the **ENTER** buttons to confirm your selection. The active window will be highlighted in yellow.

After page activation both the functions of hardware buttons and **Menu** options correspond to their functions on a given page. Pressing the **MENU** button brings up the appropriate menu for the area which is highlighted and enables all relevant page functions.



NOTE

Press and hold the **PAGE** button for more than one (1) second to change the Screen Control.

3.9.2. Menu

Pressing the **MENU** button on the **SPLIT MODE Page** activates all the commands specific to the **MAIN Menu** selections for the respective pages.

3.9.2.1. CHART Page

Please see Par. 3.3.3 for detailed function description of the **MAIN Menu** items when screen control is set to **CHART Page**.

3.9.2.2. HIGHWAY Page

Please see Par. 3.5.3 for detailed function description of the **MAIN Menu** items when screen control is set to **HIGHWAY Page**.

3.9.2.3. FISH FINDER Page

Please see Par. 3.7.3 for detailed function description of the **MAIN Menu** items when screen control is set to **FISH Page**.

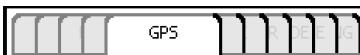

3.10. GPS PAGE

The **GPS Page** provides a visual reference of satellite acquisition, receiver status, and accuracy. This page only comes up during boot up until a GPS fix is achieved. It can be turned On in the **SYSTEM Page**, but it is Off by default, for typical Page surfing.

3.10.1. Description

The status information gives an idea of what the receiver is doing at any given moment. The sky view and signal strength bars give an indication of what satellites are visible to the receiver and whether or not they are being tracked. The signal strength is shown on a bar graph for each satellite, with the satellite number below. As a receiver locks onto satellites, a signal strength bar appears for each satellite in view.

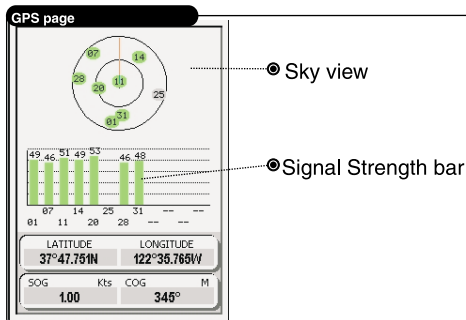

● Sky view

● Signal Strength bar

The progress of satellite acquisition is shown in three stages:

- No signal strength bars – the receiver is looking for the satellites indicated.
- Red signal strength bars – the receiver has found the satellite(s) and is collecting data
- Green signal strength bars – the receiver has collected the necessary data and the satellite(s) are ready for use.

The **GPS Page** is ready for navigation when device has collected the necessary data from at least three satellites. The sky view shows a bird-eye view of the location of each satellite relative to the receiver's last known location. The outer circle represents the horizon (north up), the inner circle 45 degrees above the horizon, and the center point a location directly overhead.

3.10.1.1. Changing Data Options

The content of each data box can be adjusted to user's requirements. To customize data options follow the procedure described in Par. 2.7.2 Changing Data Fields.



3.10.2. Menu

The **GPS Page** has its own menu, which is used for setting satellite options. To access the **MAIN Menu**, press the **MENU** button:

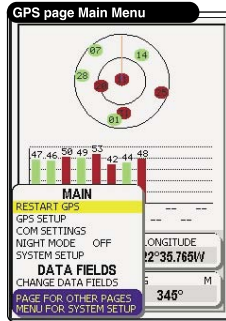

- “**RESTART GPS**”: Initializes and restarts the GPS.
- “**GPS SETUP**”: Goes to the GPS Settings in the **SYSTEM Page**.
- “**COM SETTINGS**”: Goes to the COM Settings in the **SYSTEM Page**.



NOTE

The **GPS Page** is turned OFF by default. It will be visible until a position is acquired when the chartplotter is first powered up. It must be turned ON in the PAGES ON/OFF selection from the **SYSTEM Page** (see the Par. 3.1) to view after that.

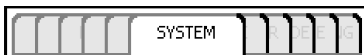

3.11. SYSTEM PAGE

The **SYSTEM Page** includes selections for the various categories of Set-Up Info.

3.11.1. Description

The picture below shows the layout of the **SYSTEM Page** with the main setting options for different functions. This section contains many settings that can be customized by the user but are usually not necessary.

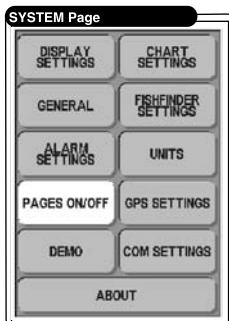

NOTE

The Fish Finder settings are grayed when unavailable.

To select a desired option use the **CURSOR** buttons, and the **ENTER** button to confirm your selection. Every sub-menu acts in the same way. Press the **ESC** button to abort given action.

3.11.2. Each Setting Description

For detailed description of all individual data fields and internal functions and features see Chapter 5.



4. ADVANCED OPERATION

4.1. MEASURE FUNCTION

The MEASURE Function allows you to measure the distance and bearing from one location to another. The starting point can either be the vessel location or the Pointer location on the chart.

1. Press the **MENU** button from one of the **CHART Pages**, select “**MEASURE**” and press the **ENTER** button.
2. Move the Pointer and the DST (Distance) and BRG (Bearing) relative to the starting location will be shown on the chart.

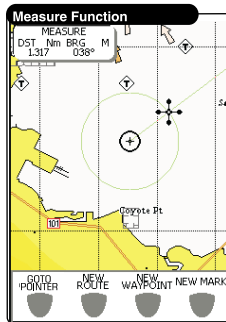

NOTE

This feature can be used for precise navigation or to quickly gauge the distance from one location to another. Move the Pointer to any location to start the “MEASURE” function from that location.

4.2. ADVANCED WAYPOINT OPERATIONS

Now that you have had a chance to become familiar with your new chartplotter, there are a great number of advanced features that you will find helpful. You may delete Waypoint from a Route, insert a Waypoint between two existing ones, move any Waypoint in the Route to another location, or modify a Waypoint.

4.2.1. Deleting a Waypoint

You can delete any Waypoint in the Route:

1. Use the **CURSOR** buttons to place the Pointer on existing Waypoint which you want to delete.



2. Press the **DELETE** software button.
3. The Waypoint is deleted and a new line between previous and next Waypoint is shown.

4.2.2. Moving a Waypoint

You can move any Waypoint in the Route to another location:

1. Use the **CURSOR** buttons to place the Pointer on existing Waypoint which you want to move.
2. Press the **MOVE** software button.
3. A dotted line, connecting the previous Waypoint position to the new position, is shown. Use the **CURSOR** buttons to move the Pointer to the desired position and press the **ENTER** button: the Waypoint is placed on the screen at the new position.

4.2.3. Inserting a Waypoint

You can insert a new Waypoint between two existing ones:

1. Use the **CURSOR** buttons to place the Pointer on the desired Route leg.
2. Press the **INSERT** software button.
3. Use the **CURSOR** buttons to move the Pointer to the new position and press the **ENTER** button: the new Waypoint is placed.

4.2.4. Editing a Waypoint

You can modify name, symbol, color and position of any Waypoint in the Route:

1. Use the **CURSOR** buttons to place the Pointer on existing Waypoint which you want to edit.
2. Press the **EDIT** software button.
3. Use the **CURSOR** buttons to modify name, symbol, Lat/Lon and color; press the **ENTER** button when finished.

4.3. ROUTE OPERATIONS

A Route is made by placing a series of Waypoints. Among the available Routes only one can be the Active Route, that is shown on the screen by straight lines and arrows to indicate the direction; the first Waypoint of this Route is surrounded by a circle. The Active Route (sometimes called current) is the working Route: it can be edited by adding, removing or moving Waypoints.



4.3.1. Selecting existing and Naming new Routes

To select the Route operations follow the procedure:

1. Press the **MENU** button from one of the **CHART Pages**, select “**ROUTES**” and press the **ENTER** button.
2. The Route table is shown on the screen.

ROUTES			
NR	NAME	DIST YD/M	LEGS
NEW ROUTE			
1	ROUTE01	19.24	2
AVAILABLE 49		USED 1	
DETAILS	DELETE	LOCATE	GOTO

3. Use the **UP** or **DOWN CURSOR** button to select the desired row. The “**NEW ROUTE**” option is highlighted, press the **ENTER** button to activate it. Another row is added for a new Route: press the **EDIT** software button to modify the Route details and the **ACCEPT** software button to accept the Route name.

4.3.2. Basic Route List Operations

After the table activation on a display, the software buttons appear on a bottom of a screen with the following options. Select the desired row and use these software buttons:

- “**DETAILS**”: Shows the Route info, you may change the name.....
- “**DELETE**”: Deletes the Route: Route legs and Waypoints are deleted. If the destination is placed on the Route, that Route cannot be deleted.
- “**LOCATE**”: Displays the selected Route on the **CHART Page**.
- “**GOTO**”: Sets the destination.



NOTE

Pressing the **MENU** button from the Route list gives various options specific to the highlighted Route or the entire list. From these commands you can Change Color, Invert, Sort, etc.



NOTE

Have you created many Routes? Using the **ZOOM+** and **ZOOM-** buttons will quickly scroll through your Route list.



4.4. USING TRACK

A very useful feature of the chartplotter, is the ability to store and display exactly where the boat has been. This feature, referred to as Tracking, can provide invaluable information about the effect of Tide and wind influence on the boat's progress as well as giving an indication of the helmsman's performance. When full storing capacity has been reached, the oldest points are deleted and overwritten by the newest ones.

To select the Track operations follow the procedure:

1. Press the **MENU** button from one of the **CHART Pages**, select **“TRACKS”** and press the **ENTER** button.
2. A new Menu window is shown on the screen.

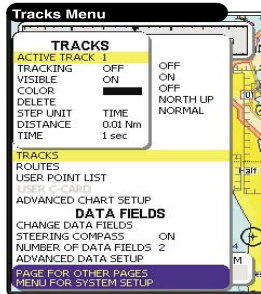

Use the **UP** or **DOWN CURSOR** button to select the desired row. The following operations are available:

NOTE

This feature is sometimes known as trail or breadcrumb trail.

- **“ACTIVE TRACK”**: Selects the number of the active Track. The default setting is 1.
- **“TRACKING”**: Turns ON or OFF the Track storing. It is not possible to use the Track storing if you are not receiving a valid fix. The default setting is On.
- **“VISIBLE”**: Turns ON or OFF the displaying of Track. The default setting is Off.
- **“COLOR”**: Selects the desired color among the sixteen colors available for the selected Track.
- **“DELETE”**: Deletes the whole Track. After pressing the **ENTER** button a warning window appears: press the **Yes** software button to confirm (press the **No** software button otherwise).
- **“STEP UNIT”**: Selects the desired step unit among DISTance (the chartplotter can store a fix when the distance from its last stored position is



User Points List

Operation

greater than a defined distance); TIME (the chartplotter can store a fix after a defined time); AUTO (the software decides when storing a position, on the basis of the straight or curved Track). The default setting is Time.

- **“DISTANCE”**: When the Tracking function is On and the step unit is set to Distance, you can store a fix when the distance from its last stored position is greater than a defined distance. Choose in the range 0.01, 0.05, 0.1, 0.5, 1.0, 2.0, 5.0, 10.0 Nm (the distance unit is selected by the user). The default setting is 0.01 Nm.
- **“TIME”**: When the Tracking function is On and the step unit is set to Time, the chartplotter can store a fix after a defined time. Choose among 1, 5, 10, 30 sec, 1, 5, 10 min. The default setting is 1 sec.

4.5. USER POINTS LIST

To give information and allow the editing of all stored User Points. Use the procedure below to select and operate the User Point List page.

4.5.1. Selecting Existing and naming new User Points

1. Press the **MENU** button from one of the **CHART** Pages, select **“USER POINTS LIST”** and press the **ENTER** button.
2. The User Points table is shown on the screen.

User Point List page

USER POINTS				
SYM	NAME	TYPE	DIST Nm	BKG M
	NEW			
✕	MRK004	MARK	8.020	355°
⏪	MRK005	MARK	10.016	046°
⚠	MRK006	MARK	6.462	097°
⊙	WPT001	WPT	13.20	041°
⊙	WPT002	WPT	5.054	115°
⊙	WPT003	WPT	2.244	234°

MOVE EDIT LOCATE GOTO

Use the **UP** or **DOWN CURSOR** button to select the User Point you wish to view or change.

3. If the "NEW" row is highlighted, pressing the **ENTER** button will create a new User Point (Mark) at the last Pointer location and give it a name in the User Point list.

4.5.2. Basic User Point List Operations

After the table activation on a display, the software buttons appear on a



bottom of a screen with the following options. Select the desired row and use these software buttons:

- **“Move”**: Moves the existed User Point. Shows the User Point on the chart in blue. Move the Pointer to the new desired location and press the **ENTER** button.
- **“Edit”**: Changes the symbol, name, type and coordinates of the selected User Point.
- **“Locate”**: Displays the selected User Points on the **CHART Page**.
- **“Goto”**: Sets the selected User Point as the destination point.



NOTE

Pressing the **MENU** button allows additional options specific to the list and to that User Point including Delete Selected, Delete by Symbol, Send, Receive, etc.



NOTE

Pressing the **RIGHT CURSOR** button shows additional information about the Waypoints and Marks in the table.

4.6. USER C-CARD OPERATIONS

The chartplotter allows to back up Marks, Routes and Tracks to a User C-CARD. This allows virtually unlimited storage. This C-CARD is available through C-MAP™ dealers. Please visit www.c-map.com for a list of dealers.

4.6.1. User C-CARD Page

To display the content of a User C-CARD inserted into the C-CARD slot of your chartplotter. To select this item follow the procedure:

1. Press the **MENU** button from the **CHART Page**. The **MAIN Menu** will be shown on the screen.
2. Use the **UP** and **DOWN CURSOR** buttons to select the **“USER C-CARD”** option.
3. The **USER C-CARD Page** is shown on the screen.

4.6.2. Formatting User C-CARD

In order to be able to use a new User C-CARD you must format it first. This operation prepares the User C-CARD to receive and store information:

1. Press the **FORMAT** software button to format the User C-CARD inserted into the slot.
2. A Warning message is shown on the screen. Press the **Yes** software button to confirm formatting of the User C-CARD (press the **No** software



button otherwise). When completed, the message "OK" is shown.



WARNING

When a User C-CARD is formatted, all data saved on it will be deleted.

4.6.3. Saving file on User C-CARD

The Save function copies the selected file from the internal memory of the chartplotter to the User C-CARD.

1. Press the **SAVE** software button to save the desired file on the User C-CARD inserted into the slot.
2. Insert the file name and type. When a certain type of data (Mark, Route, Track) is saved, a new file is created on a User C-CARD. The file contains all points of the selected type currently stored in the internal memory. When completed, the message "OK" is shown.



NOTE

When naming a file, you may have trouble finding a name that uniquely identifies the file's contents. Dates, for example, are often used in filenames; however, they take up several characters, leaving you with little flexibility. The secret is to find a compromise, a point where you can combine a date with a word, creating a unique filename. The maximum length of the filename is 8 characters. The characters may be numbers (0, ..., 9), letters (A, ..., Z) and spaces (for example legal identifiers are "ABC", "AA", "12121212", "A B C", "1 A 1", and so on.

4.6.4. Loading file from User C-CARD

The Load function copies the content of the selected file from User C-CARD to the internal memory of the chartplotter.

Press the **LOAD** software button to load the desired file from the User C-CARD inserted into the slot. If the selected file contains Marks already present in the chartplotter memory, they are non duplicated. It is required to insert the number of the Route/Track on which loading data: if the Route/Track is not empty, it is overwritten. When completed, the message "OK" is shown.

4.6.5. Deleting file from User C-CARD

To remove files. Press the **DELETE** software button to delete the desired file.



WARNING

Remember that this option permanently erases the file.



4.7. INFO

When placing the Pointer above objects on the chart, information related to the objects nearby is shown.

4.7.1. Setting Automatic Info

Automatic Info allows you to get the information on any cartographic object just by placing the Pointer on it. You can select your preferred level.

This feature is ON by default. You can turn it OFF in the Advanced Chart Settings section of the **SYSTEM Page**.



NOTE

Choosing "ON ALL" the Automatic Info will be shown most of the times the Pointer is moved.

4.7.2. Selecting Automatic Info

1. Use the **CURSOR** buttons to move the Pointer on the object.

The pop-up window with the basic info of the objects is displayed. To get full details of the object press the **EXPAND** software button.

4.7.3. Info on objects with Pictures

On the Quick Info, there is the camera icon on the top bar of the window if at least one of the objects found has one or more pictures associated.

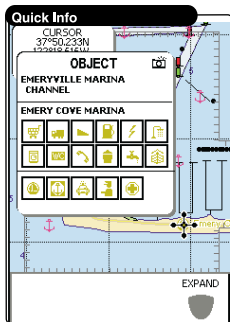

On the Full Info, there is the small camera icon on a corner of the square containing the object icon or a big photo icon centered on the square for the object without icon.



Info Current Predictions

Operation

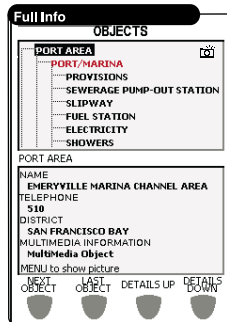

To see the picture press the **MENU** button when the object with a picture is highlighted.

4.7.4. Info Tree and Expanded Info page

The upper side of the page contains the Info Tree and the Lower side contains the expanded information. While moving the cursor through the Info Tree, all the relevant information of the selected object is shown on the lower part of the page. By pressing the **ESC** button the page is closed. If the information shown on the Lower part of the page exceeds the page size, you may scroll the page.

4.8. CURRENT PREDICTIONS



This option allows you to change any Tidal current arrows on the display to predict future conditions.

To select the Currents Prediction item follow the procedure:

1. Press the **MENU** button from one of the **CHART Pages**, select "**CURRENT PREDICTIONS**" and press the **ENTER** button.
2. A window is shown on the left side of the chart. It is possible to see the variation of the Tidal arrows on the selected area at any given time. Place the Pointer over the current arrow to show the direction and speed in the window that was appeared.
3. Use the software buttons at the bottom of the display to make predictions at the desired time.

4.9. DYNAMIC NAV AIDS



The C-MAP NT MAX™ data format allows to display animated Nav-Aids to show their correct flashing light sequence. It is possible to present Sector



Lights in the correct color based on boats position with all the Nav-Aids name displayed below the Nav-Aid symbol.

This feature is ON by default. You can turn it OFF in the Advanced Chart Settings section of the **SYSTEM Page**.



NOTE

Only Nav-Aids that are within the nominal range of the vessel are lit.

4.10. PICTURES



The C-MAP NTTM/MAXTM data format allows assigning one or more image to any chart object. These *Pictures* are typically used to facilitate the identification of cartographic objects or places around the map: they can be the landscape layout nearby a harbor, the shape of a bridge or of a buoy etc. On some objects, such as bridges, the image associated can represent the *Diagram* representing the shape of the objects and the various characteristics (length, height, type of bridge etc.).

Place your Pointer over the camera icon to show a picture.

Pictures

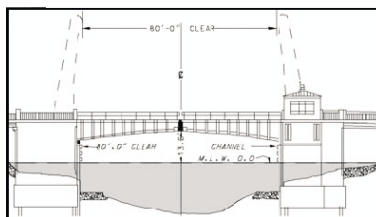

4.11. DSC CALLING



DSC (Digital Selective Calling) is a method of establishing a VHF radio call. DSC had also been designated as part of the Global Maritime Distress and Safety System (GMDSS). It is planned that DSC will be used to announce routine and urgent maritime safety information broadcasts.

This new system allow mariners to instantly send a distress call with GPS position (when connected to the transceiver) to the US Coast Guard and other vessels within range of the transmission. DSC will also allow mariners to initiate Position Request, Position Send calls to or from another vessel equipped with a DSC transceiver.



4.11.1. Advanced DSC for VHF Radio with NMEA 0183 Output

The **DSC CALLING** Page can be selected using the **PAGE** button which is generally used to scroll through all available pages: this is possible only if the **DSC CALLING** Page is turned ON in the “**PAGES ON/OFF**” menu (see Par. 3.1 for more information). See Par. 6.2.3 for VHF DSC Wiring Instructions. When the device is properly connected to a VHF radio, it is possible to receive any DSC distress call within a range. When a call is received an alert message appears at the VHF **DSC CALLING** Page.

DSC Calling page

VHF DSC CALL LOG  FOR MORE

DATE TIME	NAME MMSI	LAT LONG
03 Mar-05 14:42	Christmas 000000001	42 456781 090 453456
04 Mar-05 00:32	Lagan 000000002	42 456781 090 453456
04 Mar-05	Service Star 000000003	42 456781 090 453456

LOCATE DELETE POS REQUEST DETAILS



All the received calls are sorted by date and time. It is possible to select the whole line with the **UP** and **DOWN CURSOR** buttons. After selection the on-screen labeled software buttons are activated: **LOCATE**, **DELETE**, **POSITION REQUEST** and **DETAILS**.

4.11.2. Contact List

After pressing the **RIGHT CURSOR FOR MORE OPTIONS** button, the Contact List appears on the screen. It stores some additional information concerning *Vessel Name*, *MMSI Number*, *Name*, *Telephone*, etc. This can be used to store data for your contacts on the water.

Contact List page

DSC MMSI CONTACT LIST  FOR MORE

VESSEL NAME	MMSI NUMBER	NAME
Christmas	000000001	Dan F.
Lagan	000000002	Dan M.
Service Star	000000003	Bob
Sea Anchor	000000004	Therese

EDIT NEW DELETE DETAILS





5. SYSTEM PAGE SETTINGS

5.1. SCREEN SHOT AND DESCRIPTIONS

1. Press the **PAGE** button several times to select “**SYSTEM**” and press the **ENTER** button. The **SYSTEM Page** appears on the screen:

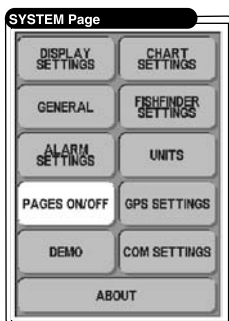

5.2. OPERATIONS BY SETTING GROUP

After the **SYSTEM Page** is shown, use the **CURSOR** buttons to select the menu you want and press the **ENTER** button. The available menus are listed in the following paragraphs.

5.2.1. Display Settings



Controls the setting of the chartplotter video screen.

- “**BACKLIGHTING LEVELS**”: Sets the desired level for backlighting.
- “**CONTRAST LEVELS**”: Sets the desired level for contrast.
- “**COLOR PALETTE**”: Sets the palette used to enhance the visibility of the screen depending on the surrounding light condition. The possible choices are **SUNLIGHT**, **NORMAL**, **CLASSIC**, **NOAA**, and **NIGHT**. **SUNLIGHT** is designed to enhance the visibility of the screen when the chartplotter is exposed to the sunlight. The maps are much brighter than in the other modes and the depth areas are filled with white color so different depth areas are not easily distinguishable. **NORMAL** is recommended when the chartplotter is not exposed to the direct sunlight. When this mode is set the maps are displayed in order to use colors as similar as possible to the ones used in the original paper charts. **CLASSIC** uses more vivid colors. **NOAA** allows setting NOAA paper chart colors presentation. **NIGHT** is recommended when the environment is dark in order to reduce the glare of



the display. The chartplotter displays maps and screens in darker colors.

HINT

It is also possible to go through the available color palettes by pressing the **PWR** button. See Par. 2.3. Press the button repeatedly to scroll through the options.

- **“BACKLIGHTING TIMEOUT”**: Sets the time value among 1, 3, 5, 10 MIN: after this time when no button is pressed, the screen and keyboard backlight is turned Off. Simply press any button or the **CURSOR** to resume normal operation. This is very useful when using the chartplotter for an anchor watch or in other scenarios where reduced power consumption is important.

CHART SETTINGS

5.2.2. Chart Settings

One of the many advantages of the C-MAP™ cartography is the ability to select the information you want to display. The user may choose either to display or not depending on his specific requirement. Use the **CHART SETTING** menu to select the cartographic objects to display on the screen. This menu is divided in the sub-menus described in the following paragraphs.

5.2.2.1. Chart Presentation

Controls the display on the map of the chart features. After the **CHART SETTINGS** menu is shown:

1. Use the **UP** or **DOWN CURSOR** button to select **“CHART PRESENTATION”** and press the **ENTER** button.
2. Use the **UP** or **DOWN CURSOR** button to select the desired option and then press the **ENTER** button. The available options are listed below:
 - **“CHART PRESETS”**: Selects from a predefined table what cartographic objects are displayed and which display options are set. Pre-programmed settings are user selectable from **FULL**, **MEDIUM**, **LOW**, **TIDES**, **CUSTOM**.
 - **“CHART ORIENTATION”**: Selects the orientation of your chart according to: **NORTH UP** (the map is shown with North upwards), **HEADING UP** (the map is shown with the ship's current heading upwards), **COURSE UP** (the map is displayed with the currently selected course leg upwards). The default setting is North Up.
 - **“DYNAMIC NAV AIDS”**: Turns **ON** or **OFF** the blinking lights on Nav-Aids. The blinking period and color of each Nav-Aid is read from the Nav-Aid attributes available on the data C-CARD. When the ship is inside the Nav-Aid nominal range, the light of the Nav-Aid will start blinking.
 - **“3D VIEW”**: Turns **ON** or **OFF** the panoramic view of the chart. Chart data



Chart Settings

Operation

may be projected in perspective mode during navigation. The upper side of the map is more compressed than the lower side, a wider map area is visible. The perspective view allows showing more chart information immediately ahead and around the Pointer.

- **“COLOR PALETTE”**: See previous Par. 5.2.1.
- **“COURSE VECTOR”**: Graphical indication of the direction in which the Vessel is heading. The Course Vector origin is the vessel's position so the time line movement is synchronized with the vessels Icon. Course Vector "course" is given by the value of COG (Course Over Ground) and its length is proportional to the SOG (Speed Over Ground). The length of the prediction line is controlled by selecting OFF, 2, 10, 30 MIN, 1 HOUR, 2 HOURS, INFINITE.
- **“BUOYS ID”**: Turns ON or OFF the displaying of the Buoy number. To better identify the Buoys, it is possible to show the name/number of the buoys next to the icon on the chart.
- **“CHART POINT NAMES”**: Turns ON or OFF the displaying of the Names (local area names).
- **“NAV AID PRESENTATION”**: Sets the Nav Aid presentation as US or INTernational. When selected it affects Lights, Signals, Buoys & Beacons display. INTernational: Draws Nav-Aids using international symbology. US: Draw Nav-Aids using NOAA symbology. All components of Complex Objects are shown.
- **“TIDES AND CURRENTS”**: Turns ON or OFF the displaying of the Tides and Currents. The new worldwide database with tidal stream information is now available with C-MAP NT MAX™ C-CARDS. When DATA/TIME is available, Tidal stream arrows are shown on the charts, indicating the direction and strength of the Tide. The colour of the arrow denotes the strength of the current as follows:

0 to 0.1 kn -		← Yellow
0.2 to 1.0 kn -		← Yellow
1.1 to 2.0 kn -		← Orange
2.1 to 3.0 kn -		← Orange
3.1 to 9.9 kn -		← Red

When the chartplotter receives a valid position fix, the Tide icons are shown on the charts on the basis of the current date and time. The arrows on the screen will rotate and change color and length as the direction and



- strength of the current changes throughout the day.
- **“PORTS AND SERVICES”**: Turns ON or OFF the displaying of the Ports and Services (areas along shore with facilities for mooring, downloading and uploading of ships, generally sheltered from waves and winds. Port installations are piers, wharves, pontoons, dry docks, cranes, etc).
 - **“TRACK AND ROUTES”**: Turns ON or OFF the displaying of the Tracks and Routes (recommended and established routes for ships at sea, including traffic separation schemes, deep water routes). Please note that these are not the same Tracks and Routes that you record and plan on your chartplotter. They are part of the chart and turning them off will choose not to show them on your screen.
 - **“VALUE ADDED DATA”**: Turns ON or OFF the displaying of the Value Added Data. The Value Added Data (VAD) is a collection of additional cartographic objects which are not present on the original paper chart (from which the electronic chart derives). These objects have been obtained from other sources (that C-MAP believes to be reliable) and then merged to the electronic charts in order to provide more information useful for the navigation. VAD object can be any cartographic objects and it can be distinguished from the official-chart-objects from the Quick Info. A dedicated icon is shown on the Quick Info window to indicate that the object queried is a VAD. The same icon is also shown on the Full Info page and in addition the extended text Value Added Data is shown on the details of the VAD object.
 - **“ADVANCED CHART SETTINGS”**: Selects the ADVANCED CHART SETTINGS menu, see the Par. 5.2.2.4.

5.2.2.2. Depth Presentation

To control the display on the map of the depth information.

After the CHART SETTINGS menu is shown:

1. Use the **UP** or **DOWN CURSOR** button to select **“DEPTH PRESENTATION”** and press the **ENTER** button.
2. Use the **UP** or **DOWN CURSOR** button to select the desired option and then press the **ENTER** button. The available options are listed below:
 - **“SHADED DEPTH AREAS”**: Turns ON or OFF the shading of desired depth areas with reference to defined minimum and maximum depth values.
 - **“DEPTH RANGE MIN”**: Sets a minimum reference for the Depth Areas.
 - **“DEPTH RANGE MAX”**: Sets a maximum reference for the Depth Areas.
 - **“ROCKS MIN”**: Sets a min reference rocks value.
 - **“ROCKS MAX”**: Sets a max reference rocks value.



5.2.2.3. Land Presentation

To control the display on the map of the land based (terrestrial) features. After the CHART SETTINGS menu is shown:

1. Use the **UP** or **DOWN CURSOR** button to select “**LAND PRESENTATION**” and press the **ENTER** button.
2. Use the **UP** or **DOWN CURSOR** button to select the desired option and then press the **ENTER** button. The available options are listed below:
 - “**LAND ELEVATION VALUES**”: The Land Elevation areas are always shown in numerical format, but it is possible to set ON or OFF the Land Elevation display in a graphical format.
 - “**ROADS**”: Turns ON or OFF the displaying of the Roads.
 - “**INTEREST POINTS**”: Turns ON or OFF the displaying of Interest Points for Shore Based Services .

5.2.2.4. Advanced Chart Settings

To control the display on the map of the advanced chart features. After the CHART SETTINGS menu is shown:

1. Use the **UP** or **DOWN CURSOR** button to select “**ADVANCED CHART SETTINGS**” and press the **ENTER** button.
2. Use the **UP** or **DOWN CURSOR** button to select the desired option and then press the **ENTER** button. The available options are listed below:
 - “**ZOOM TYPE**”: Allows larger expansion or compression of the chart scale while zooming in or out. Zoom Type has two options; **STANDARD** (default) or **FLEXI-ZOOM**. When in **FLEXI-ZOOM** mode, a short **ZOOM...** button push causes a change of chart, whilst a long **ZOOM...** button push (press and hold) causes a pop-up window to be displayed on a corner of the screen. The window shows the current Zoom Factor. By pressing the **ZOOM IN/ZOOM OUT** button the map is expanded or compressed according to the zoom factor selected. The Window is automatically closed if **ZOOM...** button is not pressed for two (2) seconds and the selected zoom factor will be used at the next zoom in/out.
 - “**LAT/LON GRID**”: Turns ON or OFF the displaying of the grid of parallels (of Latitude) and meridians (of Longitude) drawn on the map.
 - “**CHART BOUNDARIES**”: Turns ON or OFF the displaying of the Chart Boundaries, which represents the boundaries of the charts available on the chartplotter. Selecting Auto instead, if we are in background charts only the first chart levels contained in the C-CARD are displayed, if we are in a charts level contained in the C-CARD the next four charts level are displayed.



Chart Settings

Operation

- **“MIXING LEVELS”**: When the map coverage at the current zoom level does not fill the entire screen, the chartplotter draws the rest of the map expanding the cartographic information read from, at most, two zoom levels above the current zoom level. For this reason the map is drawn three times: firstly it draws the two levels before the current level and then the current level. The area covered by the cartographic data read from the previous levels is identified by a dotted pattern. When the Pointer is moved on an area not covered by data of the current level the chartplotter zooms out to the first level covered by cartographic data.



NOTE

The Mixing Levels function works only with the new C-CARDS. It also affects the speed of the redraw of the screen. If this function is not used it may be disabled.

- **“USER POINTS”**: Selections are VISIBLE, ICON and HIDDEN. Visible shows both file name and icon on the chart.
- **“AUTO INFO”**: Allows displaying information on cartographic object when the Pointer is placed on it. The Automatic Info On Points shows information when the Pointer is placed on points (as Port Services, Tides, lights, wrecks, rocks, buoys, beacons, obstructions, land markers, etc.). The Automatic Info On All shows information when the Pointer is placed on points, on lines (as Depth contours, Traffic Separation, Territorial Sea, Cartographic Lines etc.) on areas (Depth, Built-up, Sea, Attention, Restricted etc.) and on names (on the beginning of the text or on any of the characters of the name). The details on Land, Source of Data, Cartographic Area and Spot Soundings are not shown.
- **“FONTS AND SYMBOLS”**: On C-MAP NTTM/MAXTM charts it is possible to set the size of all names and symbols drawn on the charts, selecting between Normal size (the regular characters size) and Large size.

NORMAL size

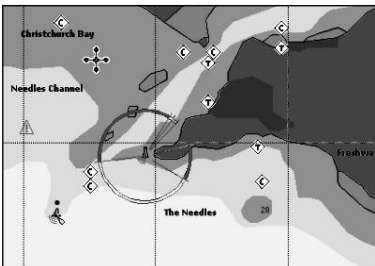

LARGE size

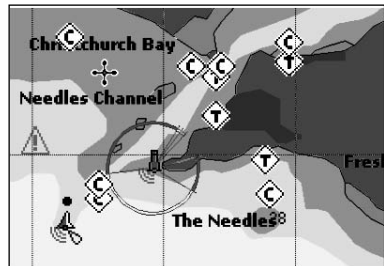



Chart Settings

Operation

- **“SCREEN AMPLIFIER”**: The Screen Amplifier function automatically offsets the map on the screen so more open area is placed “ahead” of the vessel.
- **“ORIENTATION RESOLUTION”**: It is the angle you must turn before the map will rotate (defines the maximum variation of the reference angle after which the map changes its orientation).
- **“SAFETY STATUS BAR”**: Displays a status bar with 6 fields showing the status of certain functions. Any warning or alarm condition is identified by the red colour to indicate possible risk.

Safety Status Bar



- (A) Zoom**
Normal : when the chart is displayed at normal scale.
U. Zoom : red when the chart is under-zoomed out more than twice normal scale, gray otherwise.
O. Zoom : red when the chart is over-zoomed in more than twice normal scale, gray otherwise.
Chart Lock: red when the chart is zoomed in more than twice normal scale, gray otherwise.
- (B) Best Map**
Red when a more detailed chart is available under the cursor position.
- (C) Data Off**
Red when at least one of the following objects or layers is turned off (by the user): Depths/soundings; Wrecks/obstructions; Tracks/routes; Attention areas; Nav-Aids.
- (D) Clear View**
Displays when Clear View function is On.
- (E) Dangers**
Red when “Guardian Technology” detects one of the following objects: Land, Intertidal, Depth Area, Rocks, Obstructions, Shoreline Constructions, Fishing Facility, Wrecks, Dragged area, Diffusion area, Mooring facilities, Pingos and Production installations.
- (F) Caution**
Red when “Guardian Technology” detects cautionary or restricted area.

- **“NAV AIDS”**: Turns ON or OFF the graphical presentation of Lights, Signals, Buoys and Beacons.
- **“LIGHT SECTORS”**: Turns ON or OFF the display of Light Sectors of all the Fixed Lights, Buoys and lighthouses.



- **“ATTENTION AREAS”**: Turns ON or OFF the displaying of Attention Areas (areas in which special attention by the mariner is required, because of natural or man-made hazards, or sailing regulations and restrictions. Moreover a special symbol (!) is placed inside the area selecting On option. This is valid also for the categories: FISHING FACILITY, MARINE FARM/CULTURE, MILITARY PRACTICE AREA, RESTRICTED AREA, SEAPLANE LANDING AREA. When the area is small, it is identified only by the boundary).
- **“SEABED TYPES”**: Turns ON or OFF the displaying of the Seabed Type.
- **“UNDERWATER OBJECTS”**: Turns ON or OFF the display of the Underwater Objects (objects like obstruction, wreck, cable...)

GENERAL

5.2.3. General

The GENERAL menu allows you to select some of the basic setup information.

- **“LANGUAGES”**: Selects the language in which you wish information to be displayed (for screen labels, menus and options, but it does not affect the map information).
- **“COMPASS BEARINGS”**: Selects either degrees magnetic or degrees true. If magnetic readings are selected the variation is computed automatically for every zone as soon as the chart is displayed.
- **“COMPASS VARIATION”**: Calculates the Magnetic Variation in an Automatic or manual mode, by inserting the step for calculation of Magnetic Variation.
- **“QUADRANT CALIBRATION”**: Allows you enter quadrant offsets so the GPS reading will match your boat’s magnetic compass.
- **“STATIC NAVIGATION FILTER”**: Sets a minimum speed at which movement is assumed.
- **“SIMULATED KEYBOARD”**: Turns ON or OFF the simulated keyboard for more traditional data entry.
- **“PAGES TAB”**: Turns ON or OFF the display of TAB on the top of the pages.
- **“ENGINE HOURS COUNTER”**: Allows you to enter the Engine Hours Counter menu to adjust hours and to set manual or automatic counter.

FISHFINDER SETTINGS

5.2.4. Fish Finder Settings

When the optional FISH FINDER device is connected, the Fish Finder Settings menu provides access to additional functions, setup and layout/data field options. This menu is divided in the sub-menus described in the following paragraphs.



5.2.4.1. Display Settings

To control the display settings of the video screen.

After the FISH FINDER SETTINGS menu is shown:

1. Use the **UP** or **DOWN CURSOR** button to select “**DISPLAY SETTINGS**” and press the **ENTER** button.
2. Use the **UP** or **DOWN CURSOR** button to select the desired option and then press the **ENTER** button. The available options are listed below:
 - “**BACKGROUND COLOR**”: Changes the color scheme of the Fish Finder display. The available colors are Blue Background, White Background, Black Background, Gray Scale and Reversed Gray Scale. The correct Color Bar is shown on the left for the selected setting.
 - “**SCROLLING SPEED**”: Adjusts the chart scrolling rate. Note that the scrolling rate is limited by the sound speed and the depth according to the following relation: the deeper the setting, the slower the scrolling rate. 100% is the maximum possible.
 - “**WHITE LINE**”: Controls how the chartplotter displays information about the bottom type (hard or soft).
 - “**FISH SYMBOLS**”: Determines the graphical representation of underwater suspended targets. It is possible to choose ECHO, ECHO + ICON, ECHO + ICON + DEPTH, ECHO + DEPTH, ICON, ICON + DEPTH. The Fish icons displayed are displayed using four different shapes depending on the size of the Target (Small, Med, Big, Huge).

5.2.4.2. Sensitivity Settings

The SENSITIVITY SETTINGS menu allows you to select the Fish Finder setup information.

After the FISH FINDER SETTINGS menu is shown:

1. Use the **UP** or **DOWN CURSOR** button to select “**SENSITIVITY SETTINGS**” and press the **ENTER** button.
2. Use the **UP** or **DOWN CURSOR** button to select the desired option and then press the **ENTER** button. The available options are listed below:
 - “**FISH FINDER PRESET MODES**”: Applies the following Fish Finder operating mode presets: FISH, CRUISE, AUTO RANGE, BOTTOM LOCK and MANUAL.
 - “**FREQUENCY**”: Chooses the frequency between 50 kHz or 200 kHz when single frequency page is selected.
 - “**GAIN**”: Controls the Gain of the unit’s receiver. To see more details on the screen, increase the receiver sensitivity by selecting a higher gain percentage. If there is too much detail or if the screen is cluttered, lowering



Fish Finder Settings

Operation

the sensitivity may increase the clarity of the display.

- **“NOISE TRESHOLD”**: Helps filter unwanted noise from the chart. It can be turned from 0 (no noise filtering) to 5 (maximum noise filtering).
- **“STC”**: Sensitivity Time Constant: it is a time varying gain curve which attenuates the sonar receiver gain in shallow water, increasing the gain gradually as the depth increases. This is for the purpose of filtering out surface clutter.
- **“GAIN MODE”**: Selects AUTO or MANUAL.
- **“RANGE MODE”**: Selects among MANUAL, AUTO RANGE and BOTTOM LOCK. When in Manual Range Mode it is possible to set Shift (the offset from the surface) and Depth on which the Fish Finder shall operate. When in Auto Range Mode the Fish Finder determines automatically the range as to keep the bottom visible in the lower left of the screen. In this mode, Shift is always set to 0. In Bottom Lock Mode the Fish Finder automatically tracks the range around the bottom specified by the Bottom Range value.
- **“DEPTH MODE”**: Available when Range Mode is Manual. If Depth Mode is Auto, the Fish Finder will search for the bottom in the whole depth range (0 - 4000 Feet) even if the range displayed is lower. If Range Mode is Manual, the Fish Finder will search the bottom only within the range manually set by the user. In the Range Mode the bottom search is slower because always search the whole range. In the Manual Mode the bottom search is quicker and is particularly useful when, due to extreme working conditions, the Fish Finder have some difficulties in finding the bottom.
- **“BOTTOM RANGE”**: Available when Range Mode is Bottom Lock.
- **“DEPTH”**: Available when Range Mode is Manual and it is disabled in Auto Range and Bottom Lock Mode.
- **“SHIFT”**: Available when Range Mode is Manual and it is disabled in Auto Range and Bottom Lock Mode.
- **“INTERFERENCE REJECTION”**: Selects a filter to remove interference from other Fish Finders.
- **“FREQUENCY”**: Available in the Dual Frequency page. It allows you to select the Frequency to which the Sensitivity parameters are applied.
- **“WATER TEMPERATURE”**: Controls which sensor the temp readings on the FF display come from.

5.2.4.3. Transducer Settings

The Transducer Settings menu contains settings that does not require frequent changes.

After the FISH FINDER SETTINGS menu is shown:

1. Use the **UP** or **DOWN CURSOR** button to select **“TRANSDUCER SETTINGS”** and press the **ENTER** button.



Fish Finder Settings

Operation

2. Use the **UP** or **DOWN CURSOR** button to select the desired option and then press the **ENTER** button. The available options are listed below:
 - **“KEEL OFFSET”**: Transducer depth offset from the surface. This makes it possible to measure depth from the surface or the lowest point of the keel instead of from the transducer's location. A correct negative number offset will change the depth indicated to the distance from the keel. A positive number offset will show the depth from the waterline.
 - **“CALIBRATE SOUND SPEED”**: Calibrates the value of Sound Speed in the water. The Fish Finder uses the speed of sound in water for its calculations and this speed can vary depending on the water temperature and salinity.
 - **“CALIBRATE WATER SPEED”**: Calibrates the value of Water Speed sensor. The calibration value, in the range between -10% to +10%, will be applied to the water speed from the transducer.
 - **“CALIBRATE WATER TEMP”**: Calibrates on the Water Temperature sensor. Using the readings from a precise temperature measuring device, insert here a positive/negative offset to display right value on Fish Finder screens.
 - **“CALIBRATE AUX TEMP”**: Calibrates of the Aux Temperature sensor. Using the readings from a precise temperature measuring device, insert here a positive/negative offset to display right value on FF screens.

ALARM SETTINGS

5.2.5. Alarm Settings

The chartplotter provides alarms for various functions. You can enter the desired alarm range for each function. Use the **UP** or **DOWN CURSOR** button to select the desired option and then press the **ENTER** button. The available options are listed below:

5.2.5.1. General Alarms

- **“AUDIBLE ALARM”**: Silences the key tones when pushing buttons.
- **“EXTERNAL ALARM”**: When any alarm condition occurs the pin is switched from High Impedance to ground. This signal can be used by an external device to increase the volume of the alarm. See Par 6.2.4 for more detailed wiring information.

5.2.5.2. GPS Alarms

- **“ANCHOR ALARM”**: Triggers an alarm to sound when the ship moves off the current ship's position location.
- **“ARRIVAL ALARM”**: Triggers an alarm to sound when the vessel is approaching the destination to the set distance.
- **“XTE ALARM”**: Triggers an alarm to sound when the vessel is deviating



from a defined course by the set distance.

- **“PROXIMITY ALARM”**: Triggers an alarm to sound when the destination is reached.
- **“DEPTH ALARM”**: Triggers an alarm to sound when the received depth value (from the depth transducer) is lower than the set value.
- **“GUARDIAN ALARM”**: Verifies potential danger to navigation such as shallow water (depth areas), intertidal areas, land, rocks, obstructions and shoreline constructions. The maps are scanned every ten (10) seconds. If any of the above objects are found, the chartplotter notifies the danger on a dedicated warning message box. The active "Guardian Alarms" are shown in the Guardian Alarm Report page. The chartplotter scans a sector in front of the boat. The direction is determined by the current boat heading. You can select the length and its angle is 30 degrees. The Guardian Alarm is switched Off by default after a Master Reset.
- **“GUARDIAN ALARM RANGE”**: Sets the length of the sector to be detected among 0.25, 0.5, 1.0 Nm.
- **“GUARDIAN ALARM REPORT”**: Displays the report of the dangerous objects currently detected. When any of the searched objects is found in the scanned area, a tick marker is printed on the relative box to identify which dangerous objects have been currently detected. Once the alarm condition is no longer present, the relative tick marker is removed.

5.2.5.3. Fish Alarms

- **“SHALLOW ALARM”**: Triggers an alarm when depth becomes shallower than the value set.
- **“DEPTH ALARM”**: Triggers an alarm when depth becomes deeper than the value set.
- **“TEMP UPPER”**: Triggers an alarm when the transducer reports a temperature (from TEMP 1 sensor) above the value set.
- **“TEMP LOWER”**: Triggers an alarm when the transducer reports a temperature (from TEMP 1 sensor) below the value set.
- **“TEMP RATE”**: Triggers an alarm when the transducer reports a temperature (from TEMP 1 sensor) variation rate above the value set.
- **“FIX ALARM”**: Sets the size of the fish that, if detected by the unit, switches an alarm to sound. These options are: OFF, SMALL, MEDIUM, BIG and HUGE. The alarm sounds if the set size (or bigger) is detected.

5.2.6. Units

UNITS

Allows you to select the preferred unit of measure for Distance, Speed, Depth, Altitude and Wind Speed, and also the format for Time Reference, Time Format and Date Format.



- **“DISTANCE”**: Sets the distance unit among Nm = nautical miles, Sm = status miles and Km = kilometers.
- **“SPEED”**: Sets the speed unit among Kts = knots, Mph = miles per hour and Kph = kilometers per hour.
- **“DEPTH”**: Sets the depth unit among Feet, Meters and Fathom.
- **“ALTITUDE”**: Sets the altitude unit among Ft = Feet, FL = Flight Level and Mt = Meters.
- **“TIME REFERENCE”**: Selects among Local Time or UTC. See the diagram on Par. 9.3 for entering your Local time offset. Setting this allows you to view the correct local time.
- **“TIME FORMAT”**: Sets you preferred time format among 12 Hour and 24 hour.
- **“DATE FORMAT”**: Sets you preferred date format among MM-DD-YY (month-day-year) and DD-MM-YY (day-month-year).
- **“WIND SPEED”**: Sets the wind speed unit among Kts = Knots, m/s, Kph = kilometers per hour, Bft and Mph.

5.2.7. Pages On/Off

PAGES ON/OFF

Pages can be turned ON or OFF and pressed buttons can be set from this page. Please see Par. 3.1 for detailed information.

5.2.8. GPS Settings

GPS SETTINGS

When the GPS device is connected properly, the GPS Settings menu provides the access to GPS functions and features connected with the satellites information used for further navigation. All the options are described below:

- **“INTERNAL GPS”**: Turns ON or OFF the Internal GPS.
- **“RESTART GPS”**: If GPS is connected, restarts all GPS processes. Once executed, the message "...OK" is shown. Press the **ESC** button to exit.
- **“DIFF CORRECTION SOURCE”**: If GPS is connected, sets the kind of Differential Correction used by the GPS, WAAS/EGNOS.
- **“COORDINATE SYSTEM”**: The possible choices are ddd mm ss (degrees, minutes and seconds), ddd mm.mm (degrees, minutes and hundred of minutes), ddd mm.mmm (degrees, minutes and thousands of minutes), TD (TD function allows converting GPS coordinates to Loran-C coordinates and vice versa, see TD in the Par. 9.1) and UTM (also see UTM in the Par. 9.1).
- **“FIX DATUMS”**: Sets the datum reference used by the GPS receiver connected to (or integrated in) the chartplotter so that the chartplotter converts the position received from the GPS to the Map Datum currently



selected in the menu in order to match the position from the GPS with the position on the charts. You must know what datum reference is used by the GPS and set it in the Fix Datum option.

- **“MAP DATUMS”**: Allows selecting any Geodetic Datum reference from the over 100 available on the chartplotter. Map Datum selection switches to the selected reference datum applying the datum offsets stored with the charts.
- **“FIX CORRECTION”**: Turns ON or OFF the Correction from the positioning system. If the new Correction is calculated, but the Correction is not enabled, the ship's position is not changed.
- **“MANUAL COMPUTE CORRECTION”**: Corrects fixes from the positioning instrument. By placing the Pointer on the ship's real position and selecting this option, the error is calculated and internally memorized for appropriate correction, but not applied.
- **“ENTER CORRECTION OFFSET”**: Allows manual correction of fix position. The correction is entered as X, Y offset in minutes and thousand of minutes +/- 9.999.

5.2.9. Demo

DEMO

The built-in Demo function allows you to become proficient in the use of the chartplotter. It simulates the reception of the navigation data (Lat/Lon, Course, Speed, date, time). The simulated ship's position is placed at the current Pointer position by the time the simulation is activated. This menu is divided in the sub-menus: for Demo Full and Demo a Route please see the Par. 2.5.1 and Par. 2.5.2.

5.2.9.1. Custom Demo

After the DEMO menu is shown:

1. Use the **UP** or **DOWN CURSOR** button to select **“CUSTOM DEMO”** and press the **ENTER** button.
2. Use the **UP** or **DOWN CURSOR** button to select the desired option and then press the **ENTER** button. The available options are listed below:
 - **“HEADING”**: Inserts the Heading value.
 - **“SPEED”**: Inserts the Speed value.
 - **“DATE”**: Inserts the Date value.
 - **“TIME”**: Inserts the Time value.
 - **“CURSOR CONTROL”**: Turns ON or OFF the Pointer control in the CHART Page.
 - **“ACTIVATE SIMULATION”**: Once the settings are selected, turns ON the Simulator (otherwise to turn Off the Simulation select OFF).



HINT

Another place to enter Demo is the Welcome Page (see Par. 3.2).

COM SETTINGS

5.2.10. Com Settings

Selects the proper format for the Port1/2 Input, Port1/2 Output, Port1/2 Output Sentences. Displays also the Cable Wiring page. Selects the Send/Receive Marks & Routes ports. After the COM SETTINGS menu is shown. Use the **UP** or **DOWN CURSOR** button to select the desired option and then press the **ENTER** button. The available options are listed below:

- **“PORT 1 INPUT”**: Sets the format for the navigation data input serial Port1. For example to set the Port as NMEA-0183 (4800 Baud Rate, Parity None, 8 Bits Number, 1 Stop Bit and Normal Polarity) you must select 4800-N81-N. The available choice is among NMEA-0183 1200-N81-N, NMEA-0183 4800-N81-N, NMEA-0183 4800-N82-N, NMEA-0183 9600-O81-N, NMEA-0183 9600-N81-N.
- **“PORT 1 OUTPUT”**: Sets the interface as NMEA-0183 4800-N81-N, NMEA 0180, NMEA 0180/CDX.
- **“PORT 1 OUTPUT SENTENCES”**: Allows customizing the NMEA-0183 sentence transmitted on each port. Each port can transmit a different set of sentences among: GLL, VTG, BOD, XTE, BWC, RMA, RMB, RMC, APB, WCV, GGA, HSC, HDG, APA, DBT, DPT, MTW, VHW.
- **“PORT 2 INPUT”**: Sets the format for the navigation data input serial Port2. For example to set the Port as NMEA-0183 (4800 Baud Rate, Parity None, 8 Bits Number, 1 Stop Bit and Normal Polarity) you must select NMEA-0183 4800-N81-N. The available choice is among NMEA-0183 1200-N81-N, NMEA-0183 4800-N81-N, NMEA-0183 4800-N82-N, NMEA-0183 9600-O81-N, NMEA-0183 9600-N81-N, MF 2500 Fish Finder.
- **“PORT 2 OUTPUT”**: Sets the interface as NMEA-0183 4800-N81-N, NMEA 0180, NMEA 0180/CDX.
- **“PORT 2 OUTPUT SENTENCES”**: Allows customizing the NMEA-0183 sentence transmitted on each port. Each port can transmit a different set of sentences among: GLL, VTG, BOD, XTE, BWC, RMA, RMB, RMC, APB, WCV, GGA, HSC, HDG, APA, DBT, DPT, MTW, VHW.
- **“SEND/REC ROUTES & MARKS”**: Selects the desired port between PORT 1 or PORT2 used for transferring User Points and Routes functions.
- **“CABLE WIRING”**: Shows a window containing the cable wiring.



ABOUT

5.2.11. About

To see details about the software and cartography data installed open the System Information page.



6. INSTALLATION

6.1. BASIC

This chapter provides instructions for inserting and removing C-CARD procedure, and to assist in planning the installation of the chartplotter.

6.1.1. Chartplotter Dimensions

Dimensions

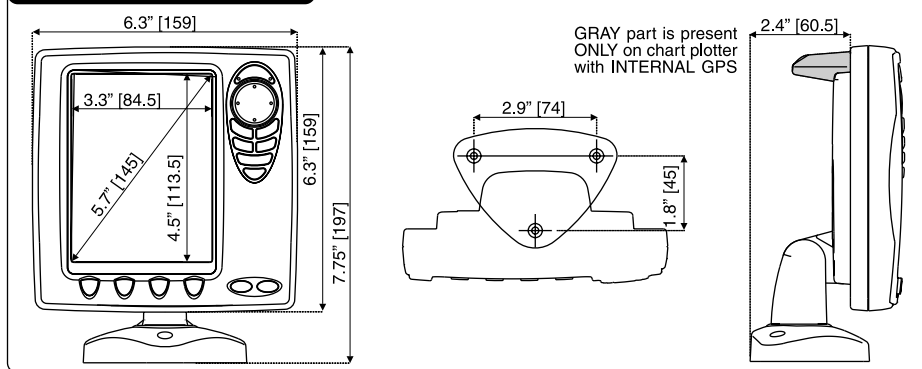

6.1.2. C-CARD Inserting and Removing

A notch for removing the cover is available on the bottom. Hold the C-CARD by the long inclined side so that you can see the C-MAP™ label. Gently push the C-CARD into the slot; push the C-CARD in as far as it will and place the front cover again.

Inserting and removing the C-CARD

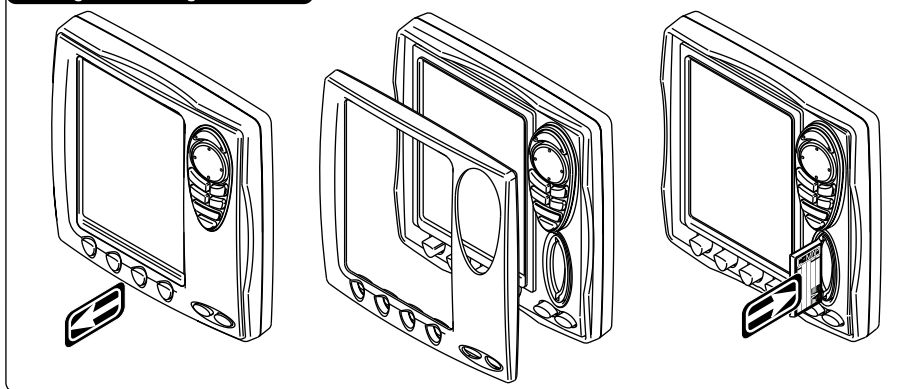



6.1.3. Chartplotter Installation and Removing

Flush Mounting

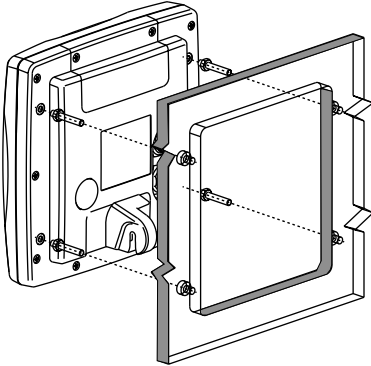

Bracket Installation

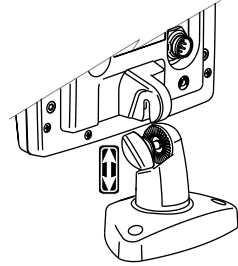

Bracket Installation

The chartplotter can be mounted using the supplied bracket. Before installing ensure the area the chartplotter's bracket is mounted to is strong enough to support the weight of the chartplotter. After the desired location is found, attach the mounting base to the area using the supplied hardware.

Flush Mounting

The chartplotter (external antenna model only) is supplied with a flush mount template for the cutout hole and screw holes required to install the chartplotter. Before installing ensure there are no obstructions behind the location that could interfere with the mounting and there is physically enough room to mount the chartplotter.

6.1.4. Wiring and Connectors

Wiring & Connectors

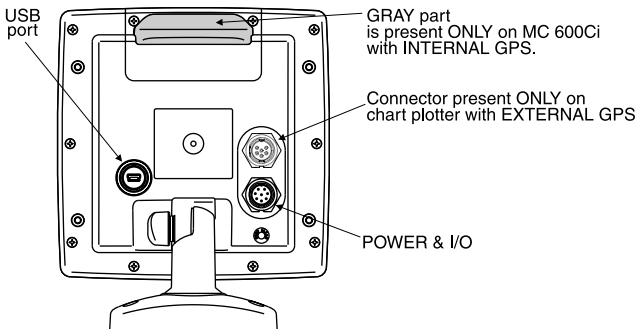



6.2. ADVANCED

The chartplotter has connectors that are used to connect the chartplotter to Power Supply, to the GPS WAAS Smart antenna, optional FISH FINDER and to NMEA devices.

6.2.1. External NMEA Connection

External NMEA Connection Port 1

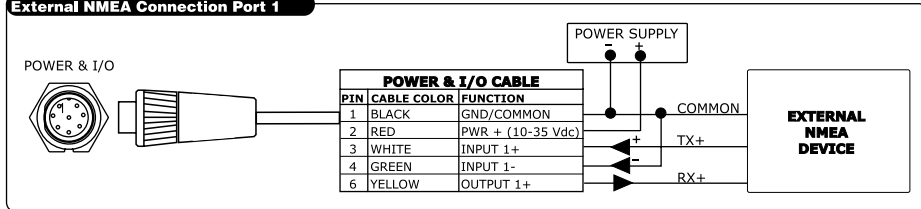

External NMEA Connection Port 2

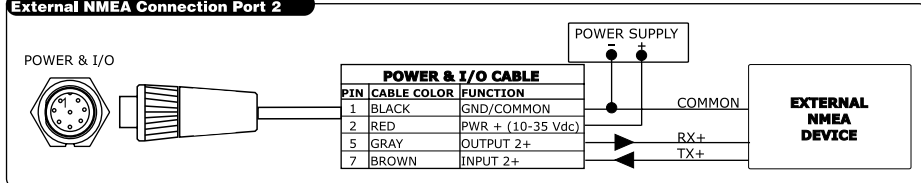

6.2.2. GPS Connection (on MC 600Cx with External GPS)

GPS Connection

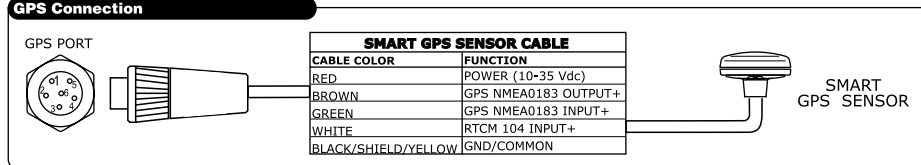

6.2.3. Autopilot and Basic DSC VHF Connection

Autopilot/DSC Connection on Port 1

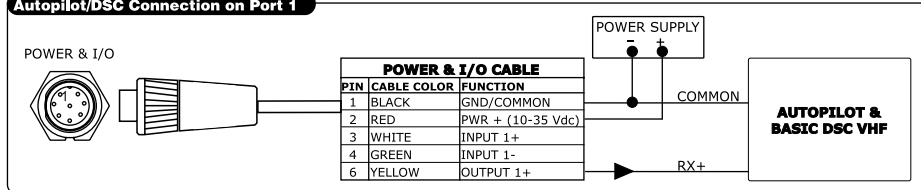



GPS Antenna

Installation

Autopilot/DSC Connection on Port 2

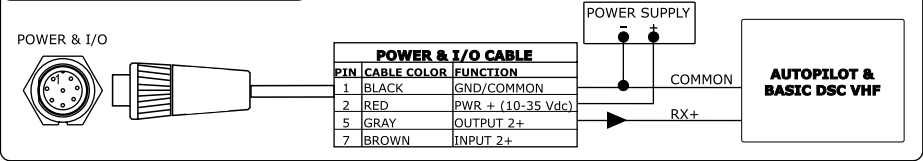

6.2.4. External Alarm Connection

External Alarm Connection

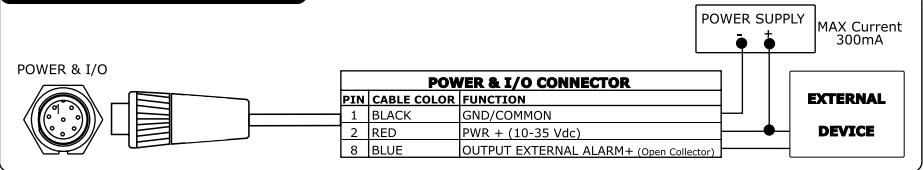

6.2.5. Fish Finder

It is possible to connect an optional FISH FINDER device. For connections and operation see the related Owner's Manual.

6.3. MOUNTING THE GPS ANTENNA (ONLY on MC 600Cx model)

The chartplotter is supplied with a 12 Channel WAAS GPS Smart antenna. This antenna is designed to be mounted on a base, installed on an extension or even flush mounted. Choose a location for the antenna that has a clear view of the sky and is not located within 3 FT of Radar or other transmitting antenna. Ensure there are no major obstructions or fixtures in the immediate proximity to the antenna. The antenna relies on direct "line of sight" satellite reception. If you are unsure of the chosen location, temporarily mount the antenna in the desired location to verify correct operation. If mounted close to Radar, and after the chartplotter has received a fix, turn On the Radar to ensure the chartplotter holds the fix (see the **GPS Page**, Par. 3.10).

The thread used on the antenna is an industry standard (1inch 14TPI) used on a wide range of mounting brackets. Due to the manufacturing process of these mounting brackets you may see some slop when tightening down the antenna to the bracket. This is no concern however as the antenna must be tightened until the antenna stops rotating.



NOTE

The antenna cable can be cut and spliced to ease installation. Care must be taken



when reconnecting the antenna cable to protect from water and corrosion. A terminal strip will also be provided for joining the wire after it is cut.

6.3.1. Antenna Flush Mounting

Before drilling holes, it is recommended the antenna be positioned where the location is planned to be drilled, cable connected to the chartplotter and the chartplotter turned On to ensure a fix is received.

For antenna flush mounting, please follow the procedure and see the picture below:

1. Remove the threaded base from the antenna dome.
2. To ease installation a flush mounting template for the antenna has been included.
3. Apply the mounting template sticker to the area that was verified for the GPS reception.
4. Drill out the 0.63" (16mm) and 0.16" (4mm) holes, and remove the template.
5. Insert the cable into the 0.63" (16mm) hole and route to the chartplotter.
6. Apply a small amount of sealant (non structural) to the under side of the antenna.
7. Place the antenna and then screw it into place using the screws. In some cases the screw may not be long enough, if this happens simply apply more sealant to the underside of the antenna to glue it into place.

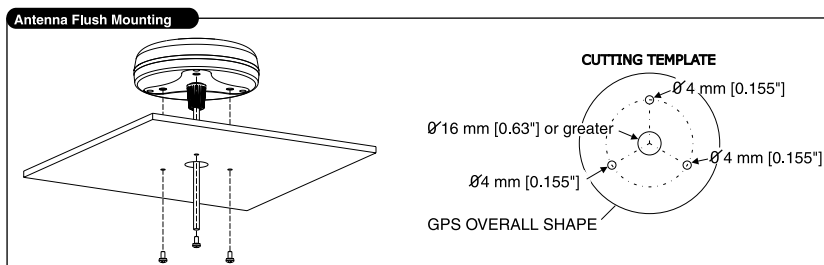



7. MAINTENANCE

This chapter gives information on routine maintenance and problem solving associated with the chartplotter.

7.1 SYSTEM TEST

If you have connected your position-finding device according to the instructions, and chosen the proper menu selection for your device, and are still having problems with your chartplotter, the extended auto-test should help determine the problem. Make sure the chartplotter is turned Off. While pressing and holding any other button, turn the chartplotter On. A new menu will appear on the display.

Use the **CURSOR** button to select the desired test: this will display in reverse video. To choose the test press the **ENTER** button. To exit from any submenu press the **ESC** button. To exit from the System Test turn Off the chartplotter.



8. OPTIONAL ACCESSORIES

8.1. PC-PLANNER

C-MAP™'s PC-PLANNER software is designed to turn your home computer into a navigational planning tool. Using the same C-MAP™ C-CARDS that you use on your boat, it is possible to display all of your electronic charts in full color on your PC screen. The PC-PLANNER can be used for viewing charts, zooming, panning, entering User Points, creating Routes, and entering Measure functions. In fact, every planning function of your chartplotter is now easy to do on your PC. This is available through your C-MAP™ dealer.

8.2. MF 2500 FISH FINDER

The chartplotter combined with the sonar performance of the MF 2500 Fish Finder is one of the most advanced marine navigation system available. The MF 2500 Fish Finder consists of a high power transmitter, sensitive receiver and a transducer. The MF 2500 Fish Finder sends an electrical pulse to the transducer which contains an element that converts the pulse into acoustic (sound) wave which is sent through the water. As this wave travels from the transducer to the bottom, it may strike fish, structures, thermoclines (temperature changes in the water). When the wave strikes an object(s) a certain amount of the wave is reflected back to the transducer depending on the composition and shape of the object. When the reflected wave is returned to the transducer it is converted into an voltage and is amplified by the receiver, processed and sent to the display. The speed of sound in water is roughly 4800 ft./sec, so the time lapse between the transmitted signal and the received echo can be measured and the distance to the object determined.

8.2.1. Transducers

The transducer is a device that transmits and receives sound waves into the water. The active component inside the transducer is commonly referred to as an element but actually is a piezoelectric ceramic material.



NOTE

Please see www.cobra.com for more information on the MF 2500 and transducer options.



9. APPENDIX

9.1. TERMS

- **ALT = Altitude**
Altitude of GPS Antenna on the medium sea level.
- **Alter = Alternate Solution (TD Coordinates System)**
Parameter selected by the user that is applied in the conversion of TD values to geographical coordinates Lat/Lon. It defines which of the two possible solutions can be used.
- **Arrival Time**
The estimated time of day you will reach your destination, based on your current Speed and Track from GPS.
- **ASF = Additional Secondary phase Factor (TD Coordinates System)**
Correction to TD values which can be inserted by the user.
- **Azimuth**
The angular measurement from the horizon to a satellite or another object.
- **AWD = Apparent Wind Direction**
The Direction from which the Wind appears to blow relative to a moving point (also called Relative Wind Direction).
- **AWS = Apparent Wind Speed**
The Speed at which the Wind appears to blow relative to a moving point (also called Relative Wind Speed).
- **Beacon**
A prominent, specially constructed object forming a conspicuous vertical mark as a fixed aid to navigation.
- **Bearings**
Selects either degrees magnetic or degrees true. If magnetic readings are selected the variation is computed automatically for every zone as soon as the chart is displayed.
- **Buoy**
A floating object moored to the sea bottom in a particular (charted) place, as an aid to navigation.
- **Buoys and Beacons**
Buoys and Beacons are used to indicate to mariners recommended or established routes, underwater dangers, restrictions and regulations. They can be lighted or not and are coloured according to their international code.
- **BRG = Bearing**
It is the angle between the North (True or Magnetic) and a destination. The



horizontal direction of one terrestrial point from another referring to the North (True or Magnetic). It is often used to indicate the direction to follow to reach the destination.

- **Chain (Loran-C GRI)**

The Loran chains are groups of transmitting stations that use timed radio pulse transmissions. In each of these chains there is a master station and two or more slave or secondary stations. Stations belonging to a same chain transmit pulses in timing groups: a different time base identifies each chain. The time base of each chain is the Group Repetition Interval or GRI. This GRI identifies the chain in unique mode. For example the GRI = 4990 identifies the chain of Central Pacific zone.

- **COG = Course Over Ground**

Direction of the path over ground actually followed by a vessel.

- **Course Line (Time Line)**

The Course Line is a graphical indication of the direction in which the Vessel is heading. The Course Line origin is the vessel's position so the time line movement is synchronized with the vessels Icon. Course Line "course" is given by the value of COG (Course Over Ground) and its length is proportional to the SOG (Speed Over Ground).

- **CTS = Course To Steer**

The optimum direction the boat should be steered in order to efficiently make headway back to the courseline while also proceeding toward the destination Waypoint.

- **Cultural Features**

Any man-made topographic feature as built-up area, buildings, roads.

- **Datum**

The Latitude and Longitude lines printed on any map are based on certain models of the shape of the earth: these models are called Datum or Coordinate Systems. There are many different Datum in use, each one gives different Lat/Lon positions for an identical point on the surface of the earth (see also Map Datum and Fix Datum).

- **Dead Reckoning**

It is the procedure to determine the current position of a vessel by applying to the last known position the way that has been made (since the last known position was received). This procedure is normally based on the last received GPS position, Speed and Course or to the last received GPS position, Log Speed and Heading.

- **Default**

Indicates the original factory setting for any menu selection. The default values are set after a Master Reset (RAM Clear).



- **Depth Area**
It is the sea area included in the (user selectable) range of minimum and maximum depth limits. The selected depth area is uniformly filled with a predefined color.
- **Depth Line**
(Also called Bathymetric Line) It is the imaginary line connecting points of equal water depth.
- **Destination**
In order to tag on the chart the point, towards which the ship is Heading, you can use a special mark, called destination. When the destination is placed, all navigation data referred to this point.
- **DGPS = Differential GPS**
Provides even greater positioning accuracy than standard GPS.
- **DPT = Depth from Transducer**
Water Depth below the Transducer. The Distance from the Depth Transducer to the ground.
- **DST = Distance**
The geographical distance between two points on the map.
- **ETA = Estimated Time of Arrival**
The predicted time of reaching a destination or Waypoint.
- **File**
Collection of information (of the same type) stored on a User C-CARD. Each file must have a unique name, ideally one that describes its contents. Filenames are kept in a directory on each User C-CARD.
- **Fix**
Current position of the vessel provided by the GPS (connected to the chartplotter or built-in) or other positioning systems.
- **Fix Status**
Indicates the quality of the position fix signal.
- **GNSS = Global Navigation Satellite System**
Name used to indicate any single or combined navigation system based on satellites. The current available satellites systems are: GPS, GLONASS and the combined GPS and GLONASS.
- **Goto**
Defines the destination point and activates the navigation to it. The destination can be placed on any location of the map, an existing Mark point or on a predefined Route.
- **GPS = Global Positioning System**
Satellite based navigation system operated by the US Department of Defense. It gives the navigator a position 24 hours a day, 365 days a year under any weather conditions.



- **HDG = Heading**
The horizontal direction in which a ship actually points or heads in any moment (see also COG).
- **HDOP = Horizontal Dilution Of Precision**
Parameter indicating the precision of the positioning system (GPS). The smaller HDOP value indicates higher position accurately.
- **Landmarks**
Any prominent object such as monument, building, silo, tower, mast, ..., on land which can be used in determining a location or a direction.
- **Latitude**
Angular distance North or South of the equator measured by lines encircling the earth parallel to the equator in degrees from 0° to 90°.
- **LAT/LON**
Coordinate system using Latitude and Longitude coordinates to define a position on earth.
- **Lat/Lon Grid**
Grid of parallels (of Latitude) and meridians (of Longitude) drawn on the map.
- **LOG Speed**
Speed of the vessel relative to the water, provided by an instrument with a submerged transducer for measuring the distance/speed traveled by the vessel.
- **Longitude**
Angular distance East or West of the prime meridian (Greenwich meridian) as measured by lines perpendicular to the parallels and converging at the poles from 0° to 180°.
- **Loran**
Positioning system which determines the current position of the vessel by measuring the difference in the times of reception of synchronized radio pulse signals transmitted by two or more fixed stations.
- **Magnetic Deviation**
Value, expressed in degrees East or West that indicates the direction in which the north indicator on the compass card is offset from the magnetic north (the difference expressed in degrees East or West between the compass north and the magnetic north).
- **Magnetic Variation**
Angle between the magnetic and geographic meridians at any place, expressed in degrees West or East to indicate the direction of magnetic North from true North. It changes from point to point, and (at the same point) with time.



- **Mark**
Reference point related to Pointer position. Typically it represents by an icon and label under Mark.
- **Natural Features**
Any topographic feature formed by the action of natural processes: coastlines, relief, glaciers.
- **NMEA-0183**
The NMEA-0183 Data Interface Standard was developed by the National Marine Electronics Association of America. It is an international standard that enables equipment from many different manufactures to be connected together and share information.
- **OSGB = Ordinance Survey of Great Britain**
Coordinate system describing only Great Britain charts. Generally used with GBR36 datum, which also describes only Great Britain charts. This coordinate system cannot be used in any other part of the world.
- **Pair**
Two selectable secondary stations, of a Loran-C chain, which are used to calculate the TD (Time Difference) position of a point in the map area covered by the selected Loran-C chain.
- **Pictures & Diagrams**
The MAX data format allows assigning one or more image to any cartographic object. These *Pictures* are typically used to facilitate the identification of cartographic objects or places around the map: they can be the landscape layout nearby a harbor, the shape of a bridge or of a buoy etc. On some objects, such as bridges, the image associated can represent the *Diagram* representing the shape of the objects and the various characteristics (length, height, type of bridge etc.).
- **Port Info**
The Port Info function is a combination of a Port Info database containing all the relevant Safety and Navigational information normally found in good pilot books and a presentation software which displays special Port Facility Symbols.
- **Ports + Services**
Areas along shore with facilities for mooring, downloading and uploading of ships, generally sheltered from waves and winds. Port installations are piers, wharves, pontoons, dry docks, cranes... .
- **Route**
Sequence of Waypoints connected by segments (Route Legs). Among the available Routes, only one is the Active Route, which is shown by a straight line and arrows to indicate the direction.



- **RTCM = Radio Technical Commission for Maritime Services**
The data format created by the Radio Technical Commission Maritime to transmit Differential GPS corrections.
- **SNR = Signal to Noise Ratio**
Ratio between the magnitude of a radio signal and the magnitude of the noise (that is, the interferences). The SRN is expressed in decibels and it is associated to the GPS satellites signal quality.
- **SOG = Speed Over Ground**
Current velocity at which the vessel is traveling, relative to a ground location. The SOG is normally provided by the GPS sensor.
- **SPD = Speed Through Water**
Speed of the vessel relative to the water.
- **Spot Sounding**
Depth of the water in a specific and charted position. It is represented on the map by its own value expressed in the current depth unit.
- **STR = Steering**
Difference between COG and CTS. If COG is 25° and CTS is 30°, then STR is 5° Right.
- **TD = Time Difference**
Loran positions are determined by precise timing of the intervals between reception of pulses transmitted by pairs of stations in the selected chain. Between any two stations a ship must be located somewhere along a line of possible positions where the measured Time Difference, TD, between arrival of pulses from those stations would be observed. The TD is measured from the time of reception of the master station signal to the time of reception of the slave station signal (see also Pair).
- **Tide**
Periodic rise and fall of the surface of oceans, bays, etc., due principally to the gravitational interactions between the Moon and Earth.
- **Tide Info**
The Tide Info feature is the combination of a new Tide heights database that will be included within new C-CARDS and new features which calculate the Tide graph for all primary and secondary ports world-wide. This function can calculate the Tide heights for any past or future date and as a by-product of this calculation will also display the Maximum and Minimum Tide height and time for the day selected plus the times of Sunrise and Sunset. At some chart levels, the chartplotter will display a new Tide Diamond Symbol for every Port or Tide point in the database covered by that particular C-CARD.
- **Tracks + Routes**
Recommended and established routes for ships at sea, including traffic separation schemes, deep water routes.



- **TRN = Turning**
Difference between COG and BRG. If COG is 80° and BRG is 75°, TRN is 5° Left.
- **TTG = Time To Go**
Estimated time needed to reach your destination, based on your current speed and the distance to destination.
- **TWD = True Wind Direction**
Direction of the Wind relative to a fixed point on the earth.
- **TWS = True Wind Speed**
Velocity of the Wind relative to a fixed point on the earth.
- **Underwater Objects**
Objects like obstruction, wreck, cable...
- **User Point**
Object you place on the chart identified by its coordinates and displayed on the screen with a reference symbol (see Mark, Waypoint).
- **UTC = Universal Time Coordinated**
Time scale based on the rotation of the earth that is used by most broadcast time services.
- **UTM = Universal Transverse Mercator**
Metric Grid system used on most large and intermediate scale land topographic charts and maps.
- **Variation**
Angle between the magnetic and geographic meridians at any place, expressed in degrees West or East to indicate the direction of magnetic North from true North. It changes from point to point, and (at the same point) with time.
- **WAAS = Wide Area Augmentation System**
The Federal Aviation Administration (FAA), in cooperation with other DOT organizations and DOD, is augmenting the GPS/SPS with a satellite-based augmentation system, the WAAS. It will provide a signal-in-space to WAAS users to support en route through precision approach navigation. After achieving initial operational capability, the WAAS will then be incrementally improved over the next years to expand the area of coverage, increase the availability of precision approaches, increase signal redundancy and reduce operational restrictions.
- **Waypoint**
Any point to which one intends to navigate. A sequence of Waypoints makes up a Route plan.
- **WGS-84 = World Geodetic System 1984**
Coordinates System or Datum developed by the Defense Mapping Agency (DMA). It is the default geodetic Datum used by the chartplotter and the GPS.



- **Zoom-In**
Shows more detail in a smaller area.
- **Zoom-Out**
Operates similarly to zoom -in, but in the reverse, showing a wider but less detailed view.
- **XTE = Cross Track Error**
Distance from the ship's present position to the closest point on a line between the origin and destinations Waypoints of the navigation.

9.2. GPS

For centuries, sailors have been searching for a reliable and precise method of traveling the world's waterways. From celestial navigating to the modern navigation techniques as Loran, Decca Navigator, Omega or Transit Satnav, each system has had its problems with weather, range and reliability. Without doubt, the "*Global Positioning System*", or GPS for short, is the most significant advance in navigation: it gives the navigator a position 24 hours a day, 365 days a year in any weather condition.

GPS is a satellite based navigation system which provides suitably equipped users with accurate position, velocity and time data.

Originally the GPS, developed by the U.S. Department of Defense, was conceived for military purposes, but now it is used in a host of civilian applications.

GPS navigation uses satellite signals to determine your position in relation to a set of satellites orbiting the earth. The GPS constellation of satellites continuously send radio signals, containing the precise position for each satellite back to earth. By knowing the position of 3 or 4 satellites and calculating various time differences between transmitted signals, the GPS receiver can determine its present position anywhere on earth, and thanks to continuous updates, calculate speed and course information.

9.2.1. How GPS Works

Currently, the GPS constellation consists of 26 orbiting satellites (including 3 spares), but this number will increase in the future.

The GPS receiver computes an accurate position by calculating the distance to the GPS satellites that orbit the earth. Signals are required from 3 satellites for two dimensional (2D) position calculation whilst 4 satellites are required for three dimensional (3D) position calculation.

As mentioned earlier, GPS satellites are not geostationary, but they are orbiting the earth as illustrated on the following figure:

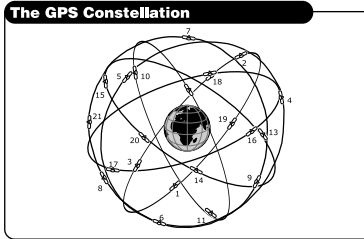

Note that position is repeatedly fixed through the following three steps while any 3 satellites are in line of sight.

The position calculation procedure is indicated in the following three steps:

1. GPS satellites continuously transmit their own precise orbital data and the GPS receiver computes their locations by receiving this data.
2. In this receiving process, the GPS receiver measures very accurate distances to the satellites, using the "Spread Spectrum Modulation" method. Excellence in GPS's position-fixing accuracy is mainly due to this technology.
3. When the satellite locations and their distances are known, the GPS receiver fixes its own position by triangulation:

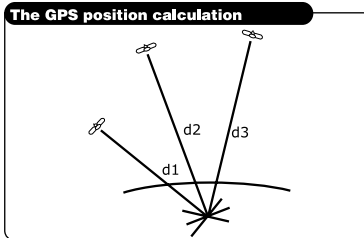

As illustrated in the previous figure, the position is calculated as the meeting point of three spheres which are drawn around the three satellites with diameters d_1 , d_2 and d_3 .

9.2.2. Position Fixing Accuracy: HDOP

The GPS fix accuracy is due to the locations of 3 satellites in the sky. High accuracy is obtainable when the satellites are widely scattered in the sky; on the contrary, accuracy is reduced when the satellites have gathered in a narrow space.

In the following figure, in both cases it is possible to obtain the GPS fix, but in the left case the accuracy will be higher than the right:

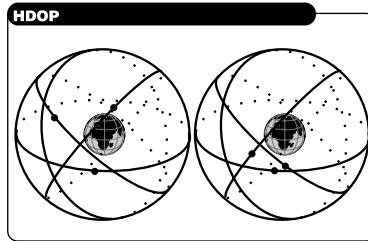

The index for position-fixing accuracy is called HDOP (*"Horizontal Dilution Of Precision"*). The smaller the HDOP value, the more accurately the position can be fixed.



9.3. WORLD CITY TIME ZONES

Longitudinal Zone	Offset	City
E 172.50 to W 172.50	-12	IDLW (International Date Line West)
W 172.50 to W 157.50	-11	Nome
W 157.50 to W 142.50	-10	Honolulu
W 142.50 to W 127.50	-9	Yukon STD
W 127.50 to W 112.50	-8	Los Angeles
W 112.50 to W 097.50	-7	Denver
W 097.50 to W 082.50	-6	Chicago
W 082.50 to W 067.50	-5	New York
W 067.50 to W 052.50	-4	Caracas
W 052.50 to W 037.50	-3	Rio de Janeiro
W 037.50 to W 022.50	-2	Fernando de Noronha
W 022.50 to W 007.50	-1	Azores Islands
W 007.50 to E 007.50 GMT	+0	London
E 007.50 to E 022.50	+1	Rome
E 022.50 to E 037.50	+2	Cairo
E 037.50 to E 052.50	+3	Moscow
E 052.50 to E 067.50	+4	Abu Dhabi
E 067.50 to E 082.50	+5	Maldives
E 082.50 to E 097.50	+6	Dhufuri
E 097.50 to E 112.50	+7	Bangkok
E 112.50 to E 127.50	+8	Hong Kong
E 127.50 to E 142.50	+9	Tokyo
E 142.50 to E 157.50	+10	Sydney
E 157.50 to E 172.50	+11	Solomon Islands
E 172.50 to W 172.50	+12	Auckland

INDEX

A			
About	75	CHART PRESETS	61
ACTIVATE SIMULATION	73	Chart Settings	61
ACTIVE TRACK	52	Cleaning	1
adjust backlight	12	CLOSEST FUEL	22
adjust contrast	12	COG	84
Advanced Chart Settings	63, 64	COLOR	52
ADVANCED CHART SETUP	26	COLOR PALETTE OPTIONS	60, 62
ADVANCED DATA SETUP	26	Com Settings	47, 74
Alarm Settings	70	COMBO MODE Page	41
ALARMS	40, 53, 70	COMPASS BEARINGS	11, 67
Alphanumeric Input	8	COMPASS VARIATION	67
ALT	83	Connection	78
Alter	83	Contact List	59
Altitude	11, 72, 83	contrast	12, 60
Analogue-Style Speedometer Gauge	27	CONTRAST LEVELS	60
ANCHOR ALARM	70	Convention	7
antenna	79	COORDINATE SYSTEM	72
Antenna Flush Mounting	80	Course Line	84
APPROXIMATE MAX SPEED	12	COURSE VECTOR	62
ARRIVAL ALARM	70	Create a Route	18
Arrival Time	83	Creating a New Mark	18
ASF	83	Creating a New Waypoint	17
ATTENTION AREAS	67	CTS	84
AUTO INFO	65	Cultural Features	84
Auto power On	10	CURRENT ENGINE HOURS	12
Automatic Info	56	CURRENT PREDICTIONS	26, 57
Autopilot Connection	78	CURSOR CONTROL	73
Available Data Options	17	Custom Demo	14, 73
AWD	83	D	
AWS	83	Data Fields	15, 16
Azimuth	83	Data Options	17
B		DATA Page	27
BACKGROUND COLOR	39, 68	DATE	73
BACKGROUND IMAGE	31	DATE FORMAT	12, 72
backlight	12, 60	DATE/TIME	32
BACKLIGHTING TIMEOUT	61	Datum	84
Beacon	83	DAY OR NIGHT MODE	23
Bearing	83	Dead Reckoning	84
BOAT MANUFACTURER	11	Default	84
BOAT MODEL	11	DEFAULT DISPLAY	29
BOAT NAME	11	DELETE	52
BOTTOM RANGE	69	Deleting file	55
Bracket Installation	77	Deleting MOB	20
BRG	83	Deleting Waypoint	49, 51
BRIGHTNESS LEVELS	60	Demo	73
Buoy	83	DEMO MODE	14, 23
Buoys and Beacons	83	DEPTH	11, 69, 72
BUOYS ID	62	DEPTH ALARM	71
buttons	7	Depth Area	85
C		Depth Line	85
C-CARD	2	DEPTH MODE	39, 44, 69
CABLE WIRING	74	Depth Presentation	63
CALIBRATE AUX TEMP	70	DEPTH RANGE MAX	63
CALIBRATE SOUND SPEED	70	DEPTH RANGE MIN	63
CALIBRATE WATER SPEED	70	DEPTH UNITS	11
CALIBRATE WATER TEMP	70	Destination	85
CAUTION	1	DGPS	85
Chain	84	Diagrams	87
Change Data Fields	16, 26	DIFF CORRECTION SOURCE	72
CHART BOUNDARIES	64	Differential GPS	85
Chart Details	2	Dimensions	76
CHART ORIENTATION	61	Display Settings	60, 68
CHART Page	24, 41, 45	DISTANCE	11, 53, 72
Chart Presentation	61	DISTANCE UNITS	11
		DPT	85
		DSC	58
		DSC CALLING	58
		DSC VHF Connection	78
		DST	85
		DUAL FREQUENCY SCREEN	39
		DYNAMIC NAV AIDS	26, 57, 61
		E	
		Echogram	35
		Editing a Waypoint	50
		ENGINE HOURS COUNTER	67
		ENTER CORRECTION OFFSET	73
		Esc back to chart	15
		ETA	85
		Expanded Info	57
		EXTERNAL ALARM	70
		External Alarm Connection	79
		External NMEA Connection	78
		F	
		file	55, 85
		FIND	19, 26
		FIND CLOSEST STATIONS	33
		FIND MARINE SERVICES	22
		FIRST TIME - GPS SETUP Page	10
		Fish Alarms	71
		FISH FINDER	35, 68, 79, 82
		FISH FINDER Page	35, 41, 45
		FISH FINDER PRESET MODES	68
		Fish Finder Settings	67
		FISH SYMBOLS	40, 68
		Fix	85
		FIX ALARM	71
		FIX CORRECTION	73
		FIX DATUMS	72
		Fix Status	85
		Flush Mounting	77, 80
		FOLLOW ROUTE	19
		FONTS AND SYMBOLS	26, 65
		Formatting User C-CARD	54
		Frequency	36, 39, 68, 69
		Full Demo	14
		G	
		GAIN	68
		GAIN MODE	39, 69
		General	67
		General Alarms	70
		GNSS	85
		Goto	19, 85
		GOTO POINT	19
		GOTO POINTER	19
		GPS	72, 85, 90
		GPS Alarms	70
		GPS ALTITUDE UNITS	11
		GPS Antenna	11
		GPS Connection	78
		GPS Settings	72
		GPS SETUP	47
		GPS STATUS Page	46
		GUAGES AND DATA	22
		GUARDIAN ALARM	71
		GUARDIAN ALARM RANGE	71
		GUARDIAN ALARM REPORT	71
		H	
		hardware buttons	7
		HdG	86
		HDOP	86, 91

HEADING	73	Pair	87	Structure	38
HIGHT WATER/LOW WATER	32	palette	13, 60	SUN AND MOON Page	32
HIGHWAY Page	30, 45	Pan	14	SUNRISE/SUNSET	32
How GPS Works	90	PC-PLANNER	82	Switching Off	10
I		PERSPECTIVE VIEW	61	Switching On	10
INFO	56	PICK A POINT	22	SYSTEM	60
Info Tree	57	Pictures	56, 58, 87	SYSTEM Page	48
Inserting a Waypoint	50	Pictures & Diagrams	87	SYSTEM SETTINGS	22
Inserting MOB	20	Play Date Forward	34	SYSTEM TEST	81
Inserting the C-CARD	76	Play Time Forward	34	T	
installation	76	PORT 1 INPUT	74	TAB	13
INTEREST POINTS	64	PORT 1 OUTPUT	74	TD	88
INTERFERENCE REJECTION	39, 69	PORT 1 OUTPUT SENTENCES	74	TEMP LOWER	71
INTERNAL GPS	72	PORT 2 INPUT	74	TEMP RATE	71
K		PORT 2 OUTPUT	74	TEMP UPPER	71
KEEL OFFSET	70	PORT 2 OUTPUT SENTENCES	74	Tide	32, 88
KEY TONE ALARM	70	Port Info	87	Tide Info	88
L		Ports + Services	63, 87	TIDES AND CURRENTS	62
LAND ELEVATION VALUES	64	power Off	10	TIME	53, 73
Land Presentation	64	power On	10	TIME FORMAT	12, 72
Landmarks	86	PRESET MODE	39	Time Line	84
language	11, 67	Q		TIME REFERENCE	12, 72
LAT/LON	86	QUADRANT CALIBRATION	67	Track	26, 52, 55
LAT/LON GRID	64, 86	R		TRACKING	52
Latitude	86	RANGE MODE	39, 69	Tracks + Routes	63, 88
LATITUDE/LONGITUDE	32	removing C-CARD	76	Transducer Settings	69
LIGHT SECTORS	66	RESET DEFAULTS	12, 40	Transducers	82
Loading file	55	RESET DEPTH LIMITS	39	TRN	89
LOG Speed	86	RESET MAXIMUM SPEED	28	TTG	89
Logo Screen	10	RESET TOTAL LOG	28	TWD	89
Longitude	86	RESET TRIP LOG	28	TWS	89
Loran	86	RESTART GPS	47, 72	U	
M		ROADS	64	UNDERWATER OBJECTS	67, 89
Magnetic Deviation	86	ROCKS MAX	63	Units	71
Magnetic Variation	86	ROCKS MIN	63	User C-CARD	53, 54
Man OverBoard	19	Route	26, 50, 55, 87	User Point	17, 65, 89
MANUAL COMPUTE CORRECTION	73	RTCM	88	USER POINTS LIST	26
map	2	S		USING FIND	19
MAP DATUMS	73	SAFETY STATUS BAR	66	USING MOB	20
MAP ORIENTATION	26	Saving file	55	USING TRACK	52
Mark	18, 55, 87	SCREEN AMPLIFIER	66	UTC	89
MEASURE	26, 49	SCREEN INSTRUCTIONS	29	UTM	89
MF 2500	82	SCROLLING SPEED	39, 68	V	
MIXING LEVELS	65	SEABED TYPES	67	VALUE ADDED DATA	63
MOB	19	Selecting an option	7	Variation	89
Moving a Waypoint	50	SEND/REC ROUTES & MARKS	74	VDM	36
MY BOAT ON CHART	22	SENSITIVITY	39	VHF DSC Call Log Page	59
N		Sensitivity Settings	68	VHF Radio	59
Natural Features	87	SHADED DEPTH AREAS	63	VISIBLE	52
NAV AID PRESENTATION	62	SHALLOW ALARM	71	W	
NAV AIDS	66	SHIFT	69	WAAS	89
Nearest Tide Station	33	SIMULATED KEYBOARD	67	WARNING	1
NEW MARK	18, 19	SNR	88	Warning Message	35
NEW ROUTE	19, 51	software buttons	7	WATER TEMPERATURE	69
NEW WAYPOINT	17, 19	SOG	88	Waypoint	12, 17, 49, 89
NIGHT MODE	26	Sonar signal	37	WAYPOINT ARRIVAL ALARM	12
NMEA 0183 Output	59	SPD	88	WELCOME Page	22
NMEA-0183	87	SPEED	11, 72, 73	WGS-84	89
NOAA	60	Speed Gauge	27	WHITE LINE	39, 68
NOISE THRESHOLD	69	SPEED UNITS	11	WIND SPEED	12, 72
N° OF DATA FIELDS	15, 26, 31	Split Mode	38	WIND SPEED UNITS	12
O		SPLIT MODE Page	44	Wiring and Connectors	77
ORIENTATION RESOLUTION	66	Spot Sounding	88	X	
OSGB	87	STATIC NAVIGATION FILTER	67	XTE	90
P		STC	69	XTE ALARM	12, 70
package	2	Steering	88	Z	
pages	13	STEERING COMPASS	26, 31	Zoom	15
PAGES ON/OFF	21, 72	STEP UNIT	52	Zoom TYPE	64
Pages selection	13	STOP NAVIGATION	26	Zoom-In	90
PAGES TAB	67	STR	88	Zoom-Out	90

**The Cobra Electronics Corporation™
line of quality products includes:**

CB Radios

microTALK® Radios

Radar/Laser Detectors

Safety Alert® Traffic Warning System

Handheld GPS Receivers

Mobile GPS Receivers

HighGear® Accessories

CobraMarine™ VHF Radios

Power Inverters

Accessories

**For more information or to order
any of our products, please visit our
website: www.cobra.com**

Nothing Comes Close To A Cobra®