

COG: 231.1  
ROT: 100.0  
PA: L  
RAIM: UNUSE

# FURUNO

## SPECIFICATIONS

### OFFICIAL NAME OF THE EQUIPMENT

U-AIS Transponder

### GENERAL

Standards  
IMO A.694(17), IMO MSC.74(69) Annex 3,  
IEC 61993-2, ITU-R M.1371-3, ITU-R M.825-3(DSC)  
CCNR Test Standard for Inland AIS

Ship reporting capacity  
2250 reports per minute, 4500 reports per minute on two channels

### TRANSPONDER UNIT

**TX/RX Frequency** 156.025 MHz to 162.025 MHz  
RX1: Default CH87B (161.975 MHz)  
RX2: Default CH88B (162.025 MHz)  
**Output Power** 1 W/ 12.5 W selectable  
**DSC Receiver** CH70 fixed, 156.525 MHz, G2B, 1200 bps  
**Bandwidth** 25 kHz/ 12.5 kHz

### DISPLAY UNIT

**Screen Size** 4.5" monochrome LCD  
**Effective Viewing Area** 95 (H) x 60 (V) mm  
**Pixel Number** 120 (H) x 64 (V)

### GPS RECEIVER

**Receiving Channels** 12 channels parallel, 12 satellites tracking  
**Rx Frequency/Rx Code** 1575.42 MHz, C/A code  
**Position Fixing System** All in view, 8-state Kalman filter  
**Position Accuracy** 10 m (HDOP ≤ 4)

### INTERFACE

**COM 1 - 4\*** IEC 61162-1/61162-2  
**Input:** VSD, SSD, ABM, BBM, ACA, ACK, AIR, DTM, GBS, GGA, GLL, GNS, HDT, LRF, LRI, OSD, RMC, ROT, VBW, VTG, PIWWWVD, PIWWWSSD, PIWWWVSD, VDM, VDO, ABK, ACA, ALR, TXT, LR1, LR2, LR3, LRF, LRI  
**Output:** \*Note: COM 4 also functions as SENSOR input  
**SENSOR (input)** IEC 61162-1/61162-2  
**COM 4 - 6**  
**Input:** DTM, GNS, GLL, GGA, RMC, VBW, VTG, OSD, HDT, GBS, ROT  
**AD-10** AD-10 format (FURUNO gyro format)  
**External Beacon** RS-232C  
**PC** RS-232C  
**10/100 Base-T Ethernet (Option)**  
**Alarm Output** Contact closure

### POWER SUPPLY

**Transponder Unit** 12-24 VDC: 7-3.5 A  
**Display Unit** 12-24 VDC: 0.3-0.15 A  
**AC/DC Power Supply Unit PR-240 (option):** 100/110/200/220 VAC, 1 Ø, 50/60 Hz

### ENVIRONMENT

**Temperature**  
**GPS Antenna Unit** -25°C to +70°C  
**Other Units** -15°C to +55°C

**Waterproofing (IEC 60529)**  
**Antenna Unit** IPX6

**Vibration (IEC 60945 ed.4)**

### EQUIPMENT LIST

- Standard**
1. Transponder Unit FA-1501 1 unit
  2. Display Unit FA-1502 1 unit
  3. GPS Antenna Unit GSC-001-E, GPA-017S-E or GPS/VHF Combined Antenna Unit GVA-100 with Distribution Box DB-1 1 unit
  4. Installation Materials 1 set

### Option

1. VHF Antenna Unit 150M-W2VN with bracket
2. Antenna Cable Kit  
For GPS/VHF Combined Antenna GVA-100  
OP24-00300: 30 m, OP24-00310: 50 m  
For GSC-001 and GPA-017S  
TNC-PS-3D-15: 15 m, CP-20-02700: 30 m, CP-20-02710: 50 m
3. Antenna Base  
CP20-01111: Pipe mount, No. 13-QA310: Offset bracket, No. 13-QA330: Deck mount, No. 13-RC5160: Handrail mount
4. Cable between Display and Transponder Unit  
MJ-A10SPF0012-050/100/250/500/1000: 5/10/25/50/100 m
5. Flush Mount Kit OP20-29: F type, OP20-17: S type
6. Pilot Plug OP24-3
7. Software for PC
8. Power Supply Unit PR-240
9. LAN Interface for PC

Note: IMO requires that the AIS operate on ship's mains (115/230 VAC) and alternative power source, then a PR-240 is required. Check with your authorities for alternative power as it can be an emergency source (AC generator) or reserve source (batteries).

## INTERCONNECTION DIAGRAM

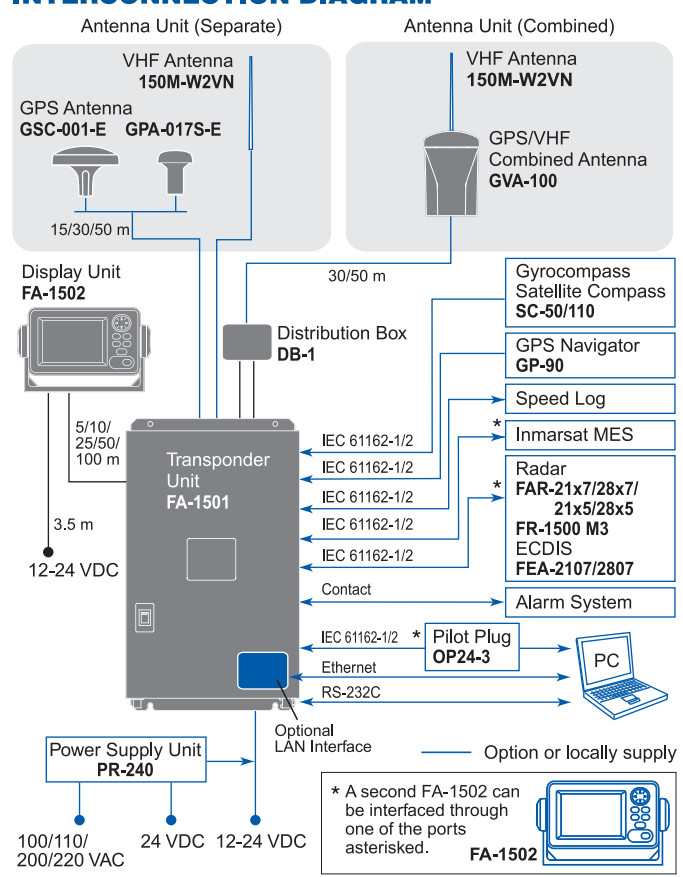

### Transponder Unit

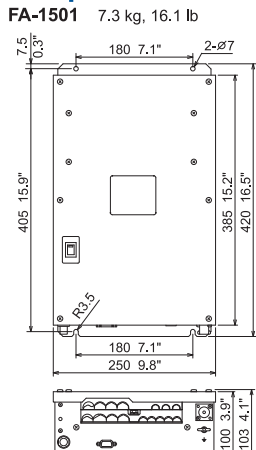

### Display Unit

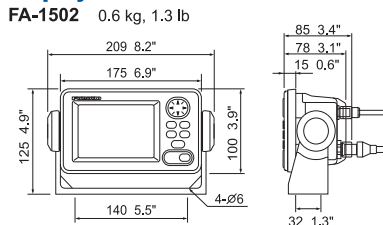

### GPS Antenna

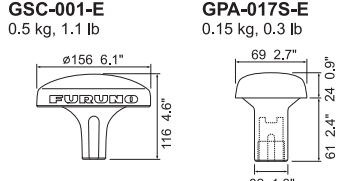

### GPS/VHF Combined Antenna

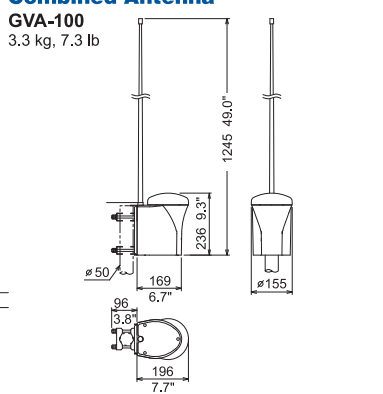

### Distribution Box

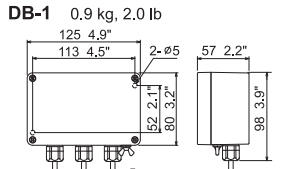

### Pilot Plug (Option)

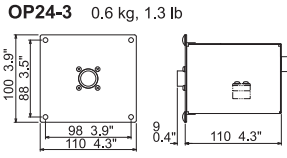

All brand and product names are registered trademarks, trademarks or service marks of their respective holders.

SPECIFICATIONS SUBJECT TO CHANGE WITHOUT NOTICE

ARM STATUS ]  
FS 10/AUG 02:09:48  
IG 10/AUG 02:09:48  
JT 10/AUG 02:09:48



# AIS

Automatic Identification System

## FA-150





## FURUNO offers reliable AIS performance for safe navigation

A Class-A Universal Automatic Identification System (UAIS) transponder, the FA-150 is designed to improve navigation safety by observing other AIS equipped ships. The FA-150 complies with relevant international regulations and standards (e.g., IMO, ITU-R, IEC) as well as national class requirements.

The FA-150 offers real-time information exchange of your own ships data and other AIS-equipped ships or coastal stations within VHF coverage. Information that is exchanged includes static, dynamic, voyage related data, as well as short safety-related messages.

The FA-150 consists of a GPS antenna, a transponder unit, a display unit and other associated equipment. The internal GPS receiver provides UTC reference for system

synchronization. It also gives position, COG and SOG if no external positioning equipment is connected. There are two types of configurations for the antenna unit: GPS and VHF combined and separate antennas. Both types of GPS antennas feature a special interference shield that allows superior performance when they are in an area of influence by equipment such as radar and satellite phones. An exceptionally compact GPS antenna is also available in the separate configuration.

The FA-150 can be interfaced with Radar and ECDIS, allowing AIS information to be displayed on them.

No additional interface units are required for connection to the latest FURUNO radar FAR-21x7/28x7 series or ECDIS FEA-2107/2807 series. Use of the WAGO connectors simplifies installation and connection.



FA-150

- ▶ Compact 4.5" silver bright display
- ▶ Full compliance with international regulations and standards
  - IMO MSC.74(69) Annex 3 • ITU-R M.1371 • IEC 60993-2
  - IEC 60945 • MTSA 2002 - U.S. AIS Requirements
- ▶ Integrates with Radar, ECDIS and Electronic Chart System
- ▶ Easy to operate
- ▶ Optional PC software
- ▶ Provides real-time AIS info for collision avoidance

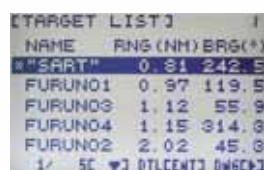

Target list



Plotter

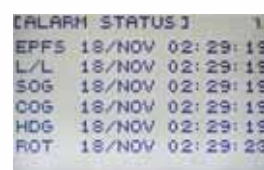

Alarm status

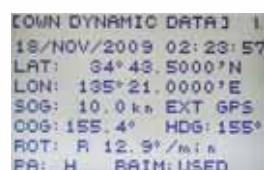

Own dynamic data

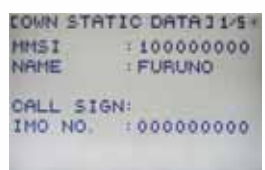

Own static data



Combined antenna



Separate GPS antennas

### AIS enhances detection of other ships and Aids to Navigation on radar and ECDIS units.

- ▶ AIS targets are visible even if they are behind large ships, islands or other landmasses
- ▶ AIS targets are not obscured by sea clutter and rain clutter
- ▶ ROT display at tip of COG/SOG vector allows navigators to predict course changes of other vessels

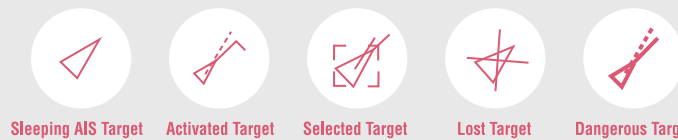

AIS COG/SOG vector changes its length with speed and a ROT mark is viewable at the COG/SOG vector tip when a target ship is equipped with a FURUNO satellite compass SC-50/110 or other compatible equipment.



FEA-2107: 20.1" LCD  
FEA-2807: 23.1" LCD

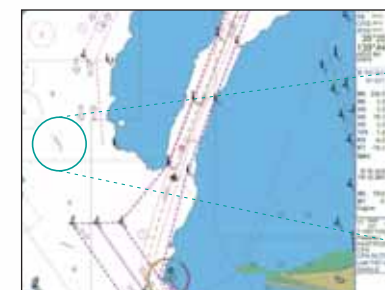

COG/SOG vector

ROT mark



FAR-21x7 series: 20.1" LCD  
FAR-28x7 series: 23.1" LCD

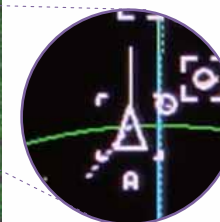

### PC software

Optional PC software is available to facilitate comprehensive observation of AIS information. With this software application, chart overlay\*, target information and targets list can be displayed on one display. \*Requires chart data

### AIS features include:

- ▶ Provides real-time AIS information for collision avoidance
- ▶ A means for coastal stations to obtain information about a ship and its cargo
- ▶ VTS tool, i.e., ship-to-shore traffic management

### Information to be exchanged

- ▶ **Static Data**
  - MMSI (Maritime Mobile Service Identity)
  - IMO number (Where available)
  - Call sign & name
  - Length and beam
  - Type of ship
  - Location of position-fixing antenna on the ship
- ▶ **Dynamic data**
  - Ship's position with accuracy indication and integrity status
  - Coordinated universal time (UTC)
  - Course over ground (COG)
  - Speed over ground (SOG)
  - Heading
  - Navigation status (manual input)
  - Rate of turn (where available)
  - Update rates Dependent on speed and course alteration (2 s - 3 min)
- ▶ **Voyage related data**
  - Ship's draft
  - Hazardous cargo (type)
  - Destination and ETA (at masters discretion)
- ▶ **Short safety-related messages**
  - Free messages

### Implementation schedule

(MSC.73 adopted on 5 December 2001 and Amendments adopted on 13 December 2002 by the Conference of Contracting Governments to the SOLAS 1974)

New build	All ships of ≥300 GT on international voyages	
	Cargo ships ≥500 GT not on international voyages	Before 1 July 2008
Passenger ships irrespective of size on all voyages		
Ships not on international voyages constructed before 1 July 2002	Passenger ships	Before 1 July 2008
	Ships, other than passenger ≥500 GT	

NOTE: All vessels in U.S. waters - Complies with MTSA 2002 (Maritime Transportation Security Act) U.S. AIS Requirements